



## **Request for Proposals – Phase I**

On or before 31 March 2009

**Under the Rural Health Care Pilot Program**



**WC Docket No. 02-60**

On behalf of RHCPP Recipients

**Adena Health System** – Chillicothe, Ohio

**Holzer Health Systems** – Gallipolis, Ohio

**O'Bleness Health System** – Athens, Ohio

and

**All SOHCN Members**



## Table of Contents

1.	Introduction and Overview	Page 3
2.	Information About Responding to the RFP	Page 7
3.	Key Contractual Relationships	Page 11
4.	Network Overview	Page 14
5.	Respondent Qualifications	Page 16
6.	Proposed SOHCN Backbone	Page 21
7.	Dedicated Bandwidth Specifications	Page 27
8.	Shared Bandwidth Solutions and Site Aggregation	Page 30
9.	Interconnection with OARnet	Page 33
10.	Internet Capacity	Page 36
11.	Data Replication Links	Page 38
12.	Location-by-Location Availability and Facility Pricing	Page 41
13.	Community Broadband Expansion	Page 43
14.	Other Terms and Conditions	Page 47
15.	Related Equipment and Professional Services	Page 53
16.	Evaluation Matrices and Contract Awards	Page 55
	Addendum: Response Templates and Tables	

# 1. Introduction and Overview

## 1.1. SOHCN Mission [Informational]

The Southern Ohio Health Care Network (SOHCN) is a consortium of health care providers organized as a 501(c)(3) serving a population of two million across thirty-four rural counties spanning 17,000 square miles of Southeast Ohio. The SOHCN service area includes the ten poorest, all six ARC-distressed and nine ARC-at-risk counties in Ohio. Federal health-care designations blanketing the SOHCN region include Health Professional Shortage Areas (HPSA), one-dozen Critical Access Hospitals (CAH) and 40+ Federally Qualified Health Centers (FQHC).

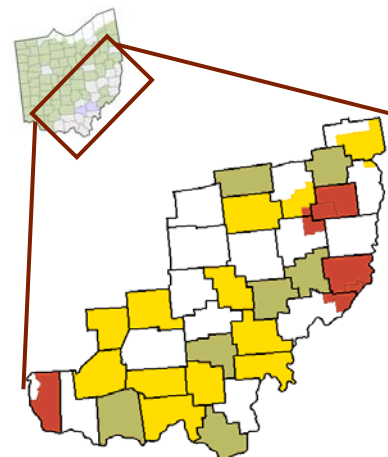

## 1.2. The Solution

The SOHCN has already been awarded \$16 million under the FCC Rural Health Care Pilot Program (FCC Pilot). With that funding we are partnering with carriers to build the SOHCN Fiber-Optic Backbone that will deliver:

1. Connection of rural health care providers, large and small, to the robust network
2. Metropolitan-class broadband services to businesses in the SOHCN communities at urban-market rates
3. Fiber-optic rings to provide the reliability necessary to support real-time health care innovations
4. Expanded residential broadband services

The overall budget picture includes:

- \$16 million in FCC funding for eligible sites
- \$2.4 million in matching funds from eligible sites
- Private funding to connect sites that are not eligible for FCC subsidy

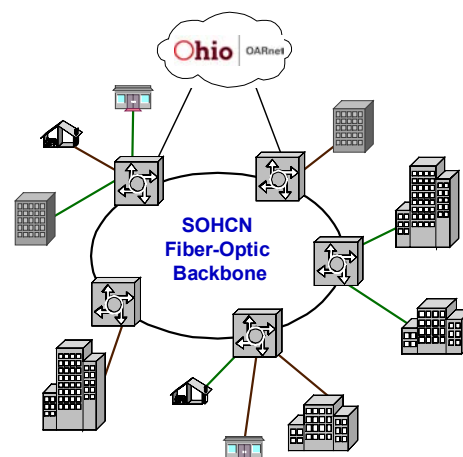

## 1.3. The Health Care Benefits

Broadband health care tools will allow the SOHCN members to improve the quality and reduce the cost of health care services through:

- Critical and intensive care consultations from urban medical centers to rural hospitals using HDTV quality picture, sound, telemetry and other clinical data
- At-home telemedicine for chronic conditions, improving health and reducing hospitalizations
- Deployment of and data exchange among electronic health record systems
- Communities of interest to share best practices and respond to public health emergencies

#### 1.4. Phase I – The Scope of this RFP [Informational]

Rather than tackle the entire SOHCN service region at one time, we have broken the project into three phases. Phase I, the focus of this RFP, consists of the following thirteen (13) counties:

- Adams
- Athens
- Fayette
- Gallia
- Highland
- Jackson
- Lawrence
- Meigs
- Pickaway
- Pike
- Ross
- Scioto
- Vinton



For Phase II and III, in addition to issuing additional RFPs, we hope to obtain additional FCC funding.

#### 1.5. Foundation of Approach [Informational]

The SOHCN seeks to fulfill its mission based on three guiding principals:

1. Provide pervasive access to broadband services for the health care entities and the community at large
2. Achieve this ambitious mission by building on and creating partnerships with Carriers
3. Deploy open architecture solutions to provide full interoperability across the SOHCN, the State of Ohio and the nation

#### 1.6. Partnership(s) with Carrier(s) [Informational]

Through this RFP, we intend to form partnerships with one or more Carriers to create and operate the SOHCN. This model features the health care providers as the “anchor tenants” to justify the investment by Carriers in our underserved region. The FCC funding provides the basis for the SOHCN Members to afford high-speed connectivity. From Carriers, we seek commitments to serve the health care facilities and to expand broadband in communities across the service region. Community broadband commitments could include:

- New types of broadband services
- Extended range of existing broadband services

## 1.7. Importance of Community Broadband [Informational]

The reasons for the SOHCN focus on improving community broadband are simple:

- a. Physician homes have emerged as a critical target for broadband deployment, providing essential after-hours coverage for rural facilities.
- b. The quality and efficiency of in-home patient care can be significantly improved by using technologies that rely on residential broadband connectivity.
- c. The financial strength of the rural health care providers depends on the overall economic well being of the region. Broadband for small businesses and residential customers provides an essential ingredient for economic growth.
- d. Widespread broadband adoption across the region will improve the long-term sustainability of health care broadband through the economies of scale.

## 1.8. Additional Files Required To Respond [Informational]

In addition to this printed document, we are providing **three files in electronic format that are required to respond** to this RFP:

1. This RFP in Word format
2. Spreadsheet in Excel format that provides response tables for all SOHCN facilities and SOHCN communities.
3. GIS Database of Phase I Locations in ERSI ArcReader format that provides:
  - Accurate mapping of all SOHCN Member facilities
  - Mapping of other potential broadband customers in the service area to demonstrate additional demand beyond the SOHCN.
  - The ability to model the region by selecting from various layer options.
  - Free reader software for download at:  
<http://www.geographymatters.com/software/arcgis/arcreader/download.html>

These additional files will be e-mailed to the Respondent RFP Contact promptly after the Respondent has identified the Respondent RFP Contact (see Section 2).

## 1.9. Definitions [Informational]

- Carrier = a generic term to describe any provider of services sought under this RFP. Examples include telephone companies, cable companies, fixed wireless providers, etc.
- Respondent = the corporate entity responding to this RFP
- POP = Point-of-Presence
- RHCPP = FCC Rural Health Care Pilot Program
- SOHCN = The Southern Ohio Health Care Network

- SOHCN Inc. = the non-profit corporation, a 501(c)3, established to manage the FCC funded project
- SOHCN POP = Point-of-Presence owned and operated by the Carrier for providing services to the SOHCN Members and to the community-at-large
- SOHCN Member = a health care organization that owns and operates one or more health care facilities that has executed a Letter of Agency (LOA) to be represented by the SOHCN
- Eligible Entities = SOHCN Members that, on an organizational level, qualify for FCC funding under the RHCPP, e.g. non-profit status
- Eligible Facilities = a health care facility owned and operated by a SOHCN Member that meets the eligibility requirements under the FCC Universal Service Fund rules. Several SOHCN Members own and operate both eligible and ineligible facilities
- Ineligible Entities = SOHCN Members that do not qualify for the FCC RHCPP funding  

For instance, Holzer Clinic is a for-profit company operating multiple facilities. The entity itself does not qualify for FCC RHCPP funding. Nonetheless, these Ineligible Entities have executed LOA's with the SOHCN to seek pricing for high-speed broadband connections.
- Ineligible Facilities = a specific facility operated by a SOHCN Member that does not qualify for FCC RHCPP funding  

For instance, Adena Health Systems as a whole is an Eligible Entity. However, Adena owns and operates a hospice that is not qualified for FCC RHCPP funding. Nonetheless, we are seeking pricing for high-speed broadband connections to these ineligible facilities.
- Community Entities = a business, school, government office, library and/or individual who might want to purchase services under the Master Services Agreement arising out of this RFP. Such Community Entities are ineligible for FCC subsidy
- Capital Buy Down = the SOHCN intends to spend the FCC RHCPP funding to buy down the capital costs for building the broadband connections to the eligible facilities, thus dramatically lowering the ongoing monthly costs for the connections over the ten (10) year term of the contracts
- **[Informational]** = Sections of the RFP provided to explain the project intent for which a response is optional
- **[Response Required]** = Sections of the RFP to which the Respondent must reply
- **[Mandatory]** = Sections that provide information that if missed by the respondent could result in disqualification of a response.

## 2. Information About Responding to This RFP

### 2.1. SOHCN RFP Contact [Informational]

The RFP Contact, identified below, is the sole point of contact regarding the RFP from the date of issuance until selection of the successful Respondent(s).

Tom Reid  
Reid Consulting Group LLC  
4 Elizabeth Drive  
Athens, Ohio 45701  
Phone: 740-590-0076  
E-Mail: Tom@ReidConsultingGroup.com



### 2.2. Respondent RFP Contact [Mandatory]

Respondents are required to e-mail or physically mail a letter to the SOHCN RFP Contact indicating the individual in your company serving as the Respondent RFP Contact. **Respondent bears full responsibility for verifying** that notification has been received and acknowledged by the SOHCN. The **Respondent RFP Contact bears full responsibility for disseminating** official communications from the SOHCN RFP Contact to the Respondent's team. Respondent may also elect to provide a list of contacts within your company to whom you would like us to copy electronic communications, which the SOHCN will accommodate on a best effort basis.

### 2.3. Questions [Mandatory]

Please direct all questions to the SOHCN RFP Contact. We prefer e-mail as the basis for contact, at least for initial inquiries. Face-to-face meetings and/or conference calls will be arranged as needed. Do not ask questions regarding this RFP of any other person associated with the SOHCN other than the RFP Contact.

When the answer to a question regarding the RFP may result in a material change to the RFP, we will respond in writing. In such cases, we will also send the question and answer to all parties that have expressed interest in responding to this RFP. Only written answers to questions will be binding.

Questions received less than seven calendar days prior to the due date may or may not be answered at the discretion of the SOHCN.

### 2.4. RFP Timeline [Mandatory]

The following dates are set forth for informational and planning purposes; however, the SOHCN reserves the right to change the dates.

Issue RFP	On or before 31 March 2009
<b>Mandatory</b> Pre-Bid Conference	Friday, 10 April 2009
Response <b>Due Date</b>	Friday, 8 May 2009

## 2.5. Mandatory Pre-Bid Conference **[Mandatory]**

A **Mandatory** Pre-Bid Conference will be held via a combination of audio and web conference technologies.

Date: Friday, 10 April 2009  
Time: 10:00 a.m. to 11:30 a.m.

Audio Bridge: 978-964-0031  
Passcode: 1500251#

Web Conference: <http://www.budgetconferencing.com/fastweb/join>  
Passcode: 1500251#

Participation in the Pre-Bid Conference is **mandatory**. The purpose of the Pre-Bid Conference is to discuss with prospective Respondents the work to be performed and provide an opportunity to ask questions regarding the RFP. Oral discussions at the Pre-Bid Conference will not be considered part of the RFP unless confirmed in writing by the RFP Contact.

## 2.6. Submit RFP Responses To: **[Mandatory]**

Tom Reid  
Reid Consulting Group LLC  
4 Elizabeth Drive  
Athens, Ohio 45701  
Phone: 740-590-0076  
E-Mail: [Tom@ReidConsultingGroup.com](mailto:Tom@ReidConsultingGroup.com)



We prefer that responses be sent via USPS, FedX, UPS or other similar carrier. If you prefer to deliver the RFP response in person, please e-mail the Contact Person to establish a drop-off appointment.

## 2.7. Time Validity of RFP Response **[Response Required]**

All pricing and terms of the Carrier's RFP response must be valid for a minimum of 180 days from the date of bid opening.

Carrier Response:

## 2.8. Number of Copies **[Mandatory]**

Submit one (1) signed original and two (2) copies of your response to this RFP in a sealed envelope or container. Respondent must also submit an electronic copy of the RFP response on USB drive, CD or DVD.

## 2.9. SOHCN Reserves the Following Rights [Informational]

1. Reject any and all responses received in response to this Request for Proposals.
2. Enter into a contract with a Carrier other than the one whose response offers the lowest cost.
3. Select the next best Carrier if negotiations with the first choice Carrier fails to result in an agreement within eight weeks after bidder selection.

## 2.10. Response Content [Mandatory]

### 1. Structure of Response

Respond to each point in the Request for Proposals, using the same outline format as in the Request for Proposals itself. All bids are to be typed on 8 1/2 x 11" paper; each page should be numbered consecutively from the beginning of the response.

### 2. Response Tables

In several locations within the RFP, the Respondent is required to complete tables and templates. In the body of the RFP, we provide examples of the response tables and templates along with instructions for each. In the Excel spreadsheet we provide the tables for response. All such response **tables and templates are to be pasted into the body of the response document**. In addition, **we also require that the response tables be submitted in Excel format** as a companion to their inclusion in the body of the response. All response tables included in the Request for Proposals and the accompanying Excel spreadsheet must be completed and returned as part of the Respondent's bid proposal. Failure to do so **may result in disqualification** of the bid.

### 3. Electronic Copy

The electronic copy should include a full PDF version of your response. In addition, we request that you submit editable versions of all related files to facilitate "what if" scenario testing and to streamline contract negotiation.

### 4. Letter of Transmittal

A cover letter must accompany each RFP response. The cover letter should include:

- Name and address of the Respondent.
- Name, address, title and telephone number of the person authorized to commit the Respondent to the RFP response.
- Name, address, title and telephone number of the person to be contacted regarding the contents of the RFP response.
- Signature of the person authorized to commit the Respondent to the RFP response.

## 5. Product Literature

Respondents may provide relevant product literature as part of the Request for Proposals response. Respondent may refer to enclosed product literature in the body of the RFP response. However, the product literature needs to be referred to specifically by publication number or by some other clear identification. In addition, the product literature needs to have an adhesive label that clearly identifies it as part of the official Request for Proposals response. Such product literature will become part of the resulting MSA and contract(s).

## 6. Corrections to Bids

Bid documents shall contain no alterations or corrections that cannot be determined to have been made prior to bid opening. An approved method of submitting material with corrections is to line out the error(s), enter the correction(s), initial and date by the authorized signer.

The following are unacceptable: submissions in pencil; submissions with erasures; submissions having applications of correction fluid, tape, etc.; and illegible submissions.

### 3. Key Contractual Relationships

#### 3.1. Master Services Agreement with the SOHCN Inc. [Response Required]

The SOHCN Inc. will execute a master services agreement (MSA) with the Carrier(s) selected to implement the SOHCN. The SOHCN Members will decide which connection options to exercise. The SOHCN MSA will in no way obligate the Southern Ohio Health Care Network to purchase any guaranteed set of products or services.

Carrier Response:

#### 3.2. Connections to SOHCN Member Facilities [Response Required]

Installation of connections under the SOHCN MSA will be as a result of contracts between individual SOHCN Members and the Carrier(s) under the terms and conditions of the SOHCN MSA(s). Beyond the capital buy down for eligible facilities, the SOHCN members are responsible for paying all costs related to the services for which they contract under the SOHCN MSA(s). In no way does the SOHCN Inc. bear responsibility for such costs, collections and/or bad debt.

Carrier Response:

#### 3.3. Connections to Community Entities in Service Area [Response Required]

The SOHCN intends to benefit the general community as well as the SOHCN Members. Explain your company's willingness to extend the terms, conditions and pricing in the SOHCN MSA to Community Entities. See detailed cost accounting requirements from the FCC regarding cross-subsidy in Section 13.3.

Carrier Response:

#### 3.4. Duration of Agreement and Contracts [Response Required]

1. The MSA between the SOHCN Inc. and the Carrier(s) shall become effective immediately upon signing by selected Respondent(s) and the SOHCN Inc.
2. The term of this MSA will be for a period of twenty (20) years, during which time SOHCN Members may purchase connections, equipment, supplies and services as specified in the bidder's response.
3. The contracts for service with SOHCN Members for connections to their facilities will be for a period of up to ten (10) years depending on when, during the term of the MSA, the SOHCN Member elects to install the connection(s) for their respective facilities.
4. All terms and conditions of the contract will remain in force over the twenty (20) year term of the MSA unless terminated earlier as specified in section 14.9.

Carrier Response:

### 3.5. Capital Buy Down Formula and Standard Rate Formula [Response Required]

In the pricing sections for connections we seek the results of two rate formulas:

- **Standard Rate Formula** = Respondent's standard approach for pricing connections.
- **Capital Buy Down Formula** = Respondent front-loads the cost of the connection by offering a one-time price that includes related capital expenses so that a lower monthly recurring price can be offered.

Carrier Response:

### 3.6. Long-Term Sustainability [Response Required]

The FCC requires that the networks built with RHCPP funds offer long-term sustainability, thus the provision for a twenty (20) year MSA. What other provisions regarding sustainability does your company offer to the SOHCN?

Carrier Response:

### 3.7. No Hidden Costs [Response Required]

The pricing provided in response to this RFP must include all costs for establishing and operating the bid connections and related network including all taxes, surcharges or other fees. No hidden costs will be accepted.

Carrier Response:

### 3.8. "Fresh Look" Provision [Response Required]

The SOHCN requests that all Respondents agree to a "fresh look" provision that allows all health care entities to renegotiate and/or terminate existing contracts. Please indicate your company's stance on such a "fresh look" opportunity for SOHCN Members already in contract with your company.

Carrier Response:

### 3.9. Early Termination Fees [Response Required]

Ideally, the SOHCN connections would all be installed within a single project year. However, due to existing contracts for lower-speed services, SOHCN connections may be installed in phases as contracts between health care organizations and existing Carriers lapse. Please indicate your company's willingness to pay early termination fees on behalf of the SOHCN Member for existing connections in order to release health care organizations from existing contracts.

Carrier Response:

### **3.10. Technology Refresh [Response Required]**

At least once per year, the Respondent will provide to the SOHCN Members revised service availability information and related pricing. Such service availability updates will address new services offered and extended geographic reach for existing services. Changes to prices for existing service offerings can only be downward.

Carrier Response:

### **3.11. Right to Upgrade [Response Required]**

During the full term of the resulting contracts, the SOHCN Members will retain the right to upgrade any connection awarded to a Respondent with a higher-speed connection from the same Respondent without early termination penalty or disconnect fee for the connection being replaced.

Carrier Response:

### **3.12. Right to Switch Providers for Higher Speeds [Response Required]**

In the event that the awarded Carrier(s) is (are) unable or unwilling to provide connections of sufficient speed to upgrade an existing service at a competitive rate, the SOHCN Members may elect to pursue other options for providing the higher speed including, but not limited to, contracting with another Respondent. In such an event, the existing connection shall be disconnected upon notice from the SOHCN Member with no early termination liability, disconnect fees and/or recovery of deferred provisioning costs from the Respondent.

Carrier Response:

### **3.13. Right to Provide Facilities to SOHCN POPs [Response Required]**

In some cases, the SOHCN or one of its members may elect to extend customer provided facilities or facilities provided by a different carrier to the Respondent's point-of-presence. Please describe your company's policies and costs for accepting customer-owned or other-carrier-owned facilities for interconnection to the SOHCN network. Please include in this discussion: fiber-optic and point-to-point wireless links; and space and power inside your POPs for customer or other-carrier-provided electronics.

Carrier Response:

## 4. Network Overview

### 4.1. Logical View [Informational]

A single connection to the SOHCN will provide the health care facility the connectivity needed for:

- Secure intra-agency communications based on encrypted VPNs established and managed using firewalls under the control of the SOHCN Member.
- “Any-to-any” connectivity within the SOHCN and OARnet with access control and encryption performed by firewalls under the control of the SOHCN Members and the external parties with whom they are communicating.
- Real-time applications supporting video and audio. Requires end-to-end network performance to meet stringent latency, packet loss and jitter performance requirements.
- Internet access.

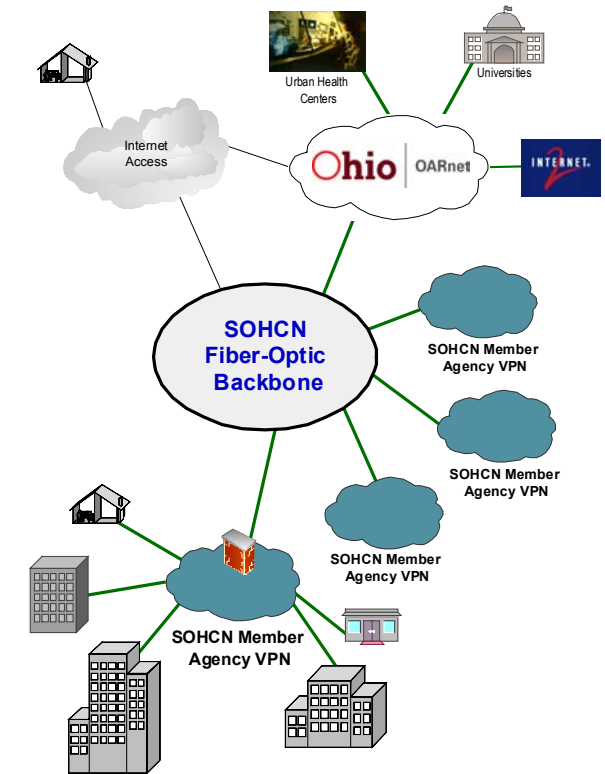

### 4.2. Physical View [Informational]

From a physical perspective, the diagram to the right illustrates a simplified view of one possible network design. The intended SOHCN features include:

- One or more fiber optic rings forming the SOHCN backbone.
- Fiber optic rings are physically diverse.
- If multiple rings are proposed, the rings must interconnect in geographically distant locations via diverse fiber paths.
- Self-healing fail-over in the event of a fiber cut in the ring.
- High capacity architecture able to meet current and future needs of the SOHCN over the next ten to twenty years.

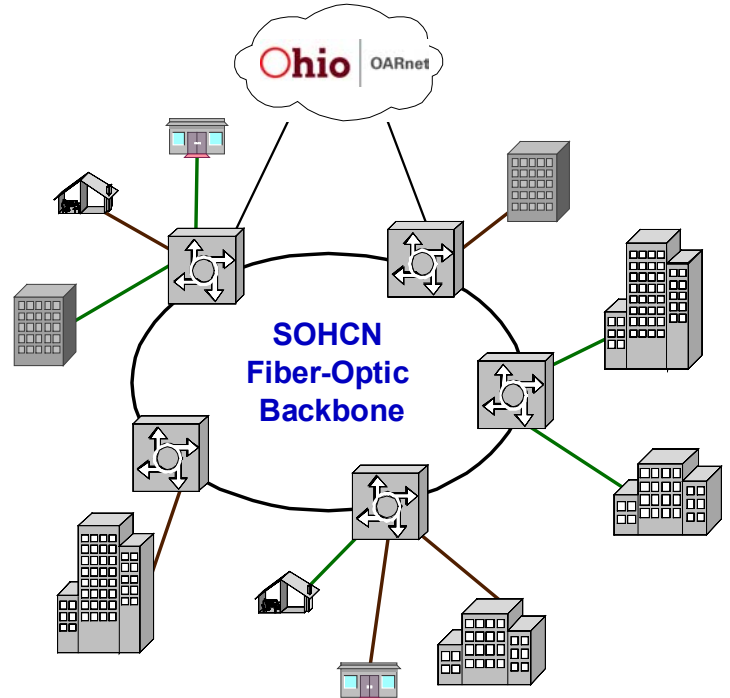

### 4.3. Classes of Connections [Informational]

The SOHCN envisions two classes of connections to serve the Members.

- **Dedicated Bandwidth** = Technologies that provide continuous, 100% bandwidth connectivity at speeds ranging from 1.5 Mbps to 40 Gbps across the SOHCN. These can be point-to-point connections or Layer 3 connections operating with mechanisms guaranteeing end-to-end operations at full port speed across the SOHCN.
- **Shared Bandwidth** = Technologies that provide burstable capacity up to the purchased port speed and guaranteed capacity at the purchased committed information rate (CIR) at speeds ranging from 1.5 Mbps to 1 Gbps.

### 4.4. Categories of Facilities [Informational]

The SOHCN has identified four categories of facilities for which we request varied levels of redundancy and connection speeds.

- **Category 1:** Regional Health Centers (100 Mbps to 10 Gbps), physical diversity as an optional add-on
- **Category 2:** Small Hospitals, Urgent Care, Emergency Room (10 Mbps to 2.5 Gbps), physical diversity as an optional add-on
- **Category 3:** Clinics, Health Departments (1.5 Mbps to 1 Gbps)
- **Category 4:** Physician Homes (1.5 Mbps to 100 Mbps)

## 5. Respondent Qualifications

### 5.1. Overview [Response Required]

Respondents are required to provide an overview of their existing network in relation to the SOHCN services. This overview should include, but not be limited to, the following topics:

1. Fiber-based network technology and architecture.
2. Existing presence in the SOHCN service area:
  - Scope of network, e.g. number of fiber route miles and strand counts, number of customer served end-points, etc.
  - Offices and employees in the SOHCN service area.
3. A map of your company's fiber network that illustrates your presence in the SOHCN service area and in neighboring geographies (protected under mutually agreeable non-disclosure agreements).

Carrier Response:

### 5.2. References [Response Required]

Respondent will provide a minimum of three (3) references from customers for whom the Carrier has performed similar work. Include the name, address, and telephone number of a contact person for each reference listed.

Carrier Response:

### 5.3. Network Resiliency [Response Required]

The facilities of the successful Respondents become by proxy a critical factor in uptime for the SOHCN networks. Thus, please explain your company's practices to insure the on-going operations of the network services proposed in your RFP response for the SOHCN Members. Your response must include, but not be limited to, a discussion of:

1. Business continuity planning, meaning measures and practices to prevent disruption to services including, but not limited to:
  - Physical security and access control
  - Back-up power
  - Fire alarming and suppression
2. Disaster recovery planning, operation and adherence to industry best practices, meaning plans and preparation for recovering from an event that impacts services. Also explain how recovery plans are tested

Carrier Response:

#### 5.4. Network Operations Center (NOC) [Response Required]

Respondents shall describe the Network Operations Centers (NOC) relevant to serving the SOHCN including:

1. Number of centers.
2. Locations serving the SOHCN.
3. Hours of operation.
4. In-sourced or out-sourced. If out-sourced, to what company are the NOC services out-sourced. Explain how terms and conditions of the Respondent's contract with the SOHCN would be translated to and enforced with the out-sourced NOC provider.
5. Minimum and average help desk/repair staffing levels. If levels differ by time of day or day of week, please explain.
6. Association to and coordination with the NOCs of incumbent carriers.
7. Association to and coordination with the OARnet NOC.
8. Proactive monitoring tools and practices.
9. The help desk/repair process, including levels of escalation.
10. Availability of access for SOHCN Members to online trouble report entry and tracking tools.
11. Availability of read-only access for SOHCN Members to online network monitoring tools.

Carrier Response:

#### 5.5. End-to-End Connection Responsibility [Response Required]

The Respondent takes end-to-end responsibility for any and all the connections provided to SOHCN Members regardless of how many subcontracted carriers contribute segments to the overall connection. The SOHCN expects that end-to-end responsibility to include the following services across all vendors:

- Coordination of connection design, provisioning, testing and troubleshooting.
- Providing a single point of contact for ordering, trouble reporting and escalation.
- Managing network management, monitoring and alarming.
- Submitting a single monthly invoice for the entire connection.

Carrier Response:

### 5.6. Inside Wiring **[Response Required]**

At the SOHCN Member’s request, end-to-end responsibility will extend to inside wiring from the point of demarcation to the specified location inside the SOHCN Member facility.

Carrier Response:
-------------------

### 5.7. Partners and Subcontractors **[Response Required]**

Respondents are required to divulge all partners and subcontractors to be utilized in providing the proposed SOHCN network connections and related services. In this section we are seeking partners and subcontractors providing ongoing network related services, e.g. secondary carriers. Fill out a copy of the template below for each partner or subcontractor.

Company Name	[Corporate Name]
Carrier ID	[ID]
Role	[Role]

#### Instructions:

[Corporate Name] = the company name of the partner or subcontractor.

[ID] = the abbreviation of the company name that you will use elsewhere in your response to indicate that services are provided by this company.

[Role] = the role of each partner or subcontractor, e.g. “Providing last mile connections to SOHCN facilities.”

Carrier Response: <b>&lt;Insert completed templates&gt;</b>
Carrier Narrative:

### 5.8. Seamless Interconnection **[Response Required]**

For partners and subcontractors included in your response, explain how you will guarantee seamless interconnection among all SOHCN Facilities.

Carrier Response:
-------------------

### 5.9. Carrier Cooperation **[Response Required]**

In the event that more than one Respondent is awarded contracts under this RFP and the resulting MSAs, explain how you will guarantee full and timely cooperation and seamless interconnection with the other awardee(s).

Carrier Response:
-------------------

**5.10. Service Restoration [Response Required]**

When connection failures occur in the SOHCN, the impact on the SOHCN Members can be extreme. The more successful the SOHCN Members become in expanding the use of health care information technology, the more dramatic the impact of an outage. Thus Respondent responsiveness becomes a critical factor in awarding this contract. The following table lists some of the logical stages of a service outage.

Respondents must provide contractually meaningful “not to exceed” timelines in the table below.

Outage Sequence	Respondent Response Time Commitment
Respondent monitoring system detects outage (minutes)	
Respondent notifies the affected SOHCN Member(s) of outage (minutes)	
Respondent commences repairs (minutes)	
Respondent provides status updates to the affected SOHCN Member(s) (every "x" hours)	
Network equipment failure maximum outage (hours)	
Fiber cut maximum outage (hours)	
Respondent provides post-outage briefing to the affected SOHCN Member(s) (hours)	

In addition to completing the table above, please describe:

1. The measures in place to facilitate rapid recognition and resolution of outages within your company and network.
2. Methods for notification to the SOHCN Member(s).
3. Location and quantity of:
  - Technical personnel
  - Fiber restoration teams and coverage areas
  - Pertinent parts depots

Carrier Response:
-------------------

**5.11. Definition of Outage [Response Required]**

The term “**outage**” shall mean the period during which there is loss of availability of any service or service elements. Outages are not specifically limited to total loss of availability or discontinuance of service. Outages shall also mean the period during which a service or service element is degraded to the point that it fails to meet its performance specification as defined in the SLA sections of the service-specific responses.

Carrier Response:
-------------------

**5.12. Escalation Process [Response Required]**

Define the severity codes and priorities established in your escalation processes for trouble and repair classifications. At least three (3) levels of escalation are to be described in detail. Include the associated conditions and notifications that apply at each level of escalation.

Carrier Response:

**5.13. Chronic Problem Resolution [Response Required]**

Describe your processes for proactively identifying and tracking chronic problems. Define chronic.

Carrier Response:

**5.14. Credits for Service Outages [Response Required]**

To compensate the SOHCN Members for service failures, bidders are expected to offer credits for service outages issued as credits to invoices. The SOHCN expects such credits to escalate for outages that exceed the limits agreed to in 5.10. In the table below, the Respondent is to provide the basis upon which monetary service credits will be calculated.

SPECIFICATION		Carrier Credit Commitment
Resolution within the maximum outage durations times stipulated in 5.10.	Prorate credit based on:	
Prorated credit with escalating multiples based on the hours outside the response time limits set in 5.10.	First hour multiplier:	
	Second hour multiplier:	
	Third hour multiplier:	
	Fourth hour multiplier:	
	Fifth hour multiplier:	
	Additional hours multiplier:	

Instructions:

In the first row, the Respondent is to indicate the unit of measurement for the Carrier Credit Commitment, for instance, "Value of one day of service charge for each hour of outage time."

In the remaining rows, the Respondent is to indicate the multiplier applied to the Carrier Credit Commitment for outages that exceed the maximum outage duration times stipulated in 5.10.

Carrier Narrative:

## 6. Proposed SOHCN Backbone

### 6.1. Network Architecture [Response Required]

Provide an overview of the design offered by your company for the SOHCN network architecture and topology.

Carrier Response:

### 6.2. Defining Physical Diversity [Response Required]

To answer in the affirmative regarding physical diversity in this RFP, the Respondent must provide fiber paths with zero (0) route miles in/on the same:

- Sheath
- Conduit
- Pole
- Manhole
- Geo-path with a minimum separation of one hundred (100) feet on the route and twenty (20) feet on the building entrance.

This definition of Physical Diversity applies and is binding to all mentions in this RFP and in the Carrier's response of:

- Physical Diversity
- Diverse Route
- Diverse Entry
- Any other description or depiction of physical diversity

Carrier Response:

### 6.3. Physical Diversity Requirements [Response Required]

The SOHCN seeks diversity based on physical paths and electronics as illustrated in the following diagram. Pictured are the SOHCN Backbone and three connection options.

#### The SOHCN Backbone

The SOHCN Backbone, whether consisting of one ring or multiple rings, must be physically diverse both in the fiber entry to the POP and the routes between POPs.

#### Scenarios for Member Sites Requiring Diversity

For SOHCN Member sites where time sensitive remote medical care may be administered, we also seek redundancy based on three scenarios described in the following text and diagram.

▪ **Scenario A**

The Carrier establishes a POP in the community to serve SOHCN Member facilities and to provide community broadband services. Two diverse fiber routes are extended to the SOHCN facility(ies) that require redundancy.

▪ **Scenario B**

The SOHCN Backbone passes through the SOHCN facility. Optical-ring interface electronics are in place in the SOHCN Member facility to serve that facility's needs only. The Carrier also establishes a POP in the community to serve other SOHCN Member facilities and for providing community broadband services. In addition, a diverse fiber path is built from the SOHCN facility to the POP to provide further redundancy in the event that the optical ring electronics in the SOHCN facility fail.

▪ **Scenario C**

The SOHCN Backbone passes through the SOHCN facility. The Carrier establishes a POP in the SOHCN facility. In addition to serving the hosting SOHCN facility, the Carrier extends services from this POP to serve other SOHCN Member facilities and provide community broadband services.

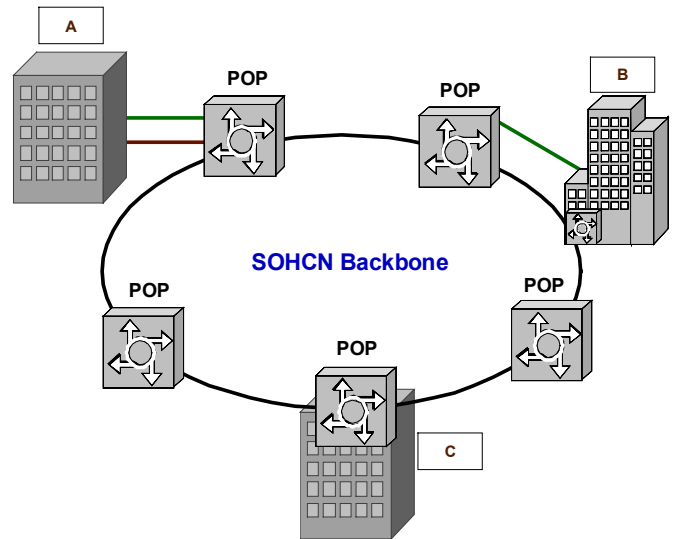

Carrier Response:

**6.4. Respondent Fiber Route Maps [Response Required]**

Respondents must disclose detailed fiber route maps for the fiber optic cables proposed to create the SOHCN's Backbone in order to demonstrate that physical diversity needs are met. Indicate on the fiber route maps which segments are owned by the Respondent and which are leased from other companies. Such disclosure will be governed by mutually agreeable non-disclosure agreements.

Carrier Response:

**6.5. Map of the Backbone [Response Required]**

Provide a detailed map of the network facilities that will serve the SOHCN Backbone including fiber routes and POP locations.

Carrier Response:

### 6.6. Optical Layer [Response Required]

Explain the design offered by your company for the optical layer technology, including, but not limited to:

1. Speeds
2. Growth of capacity over time

Carrier Response:

### 6.7. Layer 3 Solution [Response Required]

Explain the design offered by your company for the OSI Layer 3 solution for providing connectivity for SOHCN Members, including, but not limited to:

1. Interface options
2. Speeds
3. Quality of service mechanisms
4. Support for jumbo frames, e.g. 10 KB versus 1.5 KB
5. List of functions supported, e.g. BGP, OSPF, trunking of connections

Carrier Response:

### 6.8. Data Replication Links [Response Required]

Explain the design offered by your company for the solution for providing data replication links.

Carrier Response:

### 6.9. Isolation from Commercial Traffic [Response Required]

Explain the design offered by your company to isolate SOHCN traffic from commercial traffic on your network.

Carrier Response:

### 6.10. Peering to Other Providers [Response Required]

Explain the design offered by your company to peer the SOHCN to:

1. Incumbent networks in the region
2. Tier 1 Internet service providers
3. OARnet

Carrier Response:

### 6.11. Levels of Redundancy in POPs serving the SOHCN [Response Required]

The SOHCN members intend to conduct mission critical business including real-time patient care across the network. Thus the detail regarding Carriers' network redundancy becomes a critical criterion. The following three examples indicate the level of detail we seek from Respondents in explaining how redundancy is provided.

#### Example 1: Fully Redundant Electronics

In this example, both the opto-electronics and the customer access router segments of the POP enjoy full redundancy including separate chassis.

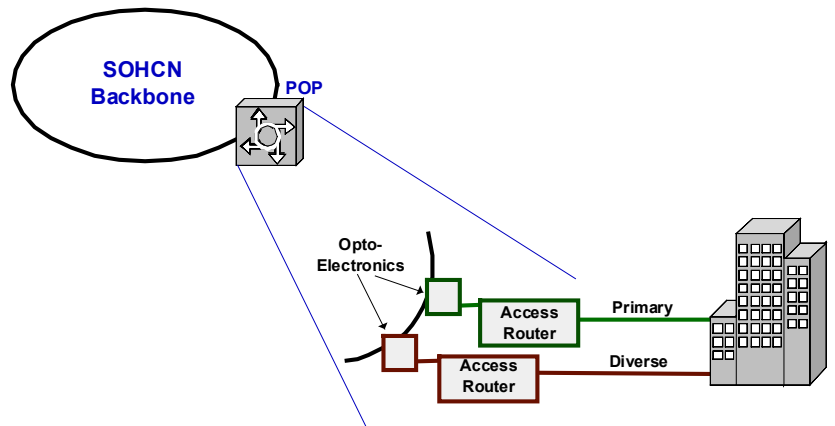

#### Example 2: Redundant Opto-Electronics Only

In this example, the opto-electronics enjoy full redundancy including separate chassis. A single access router chassis serves both the primary and diverse connections. The access router may have internal redundancy within the chassis.

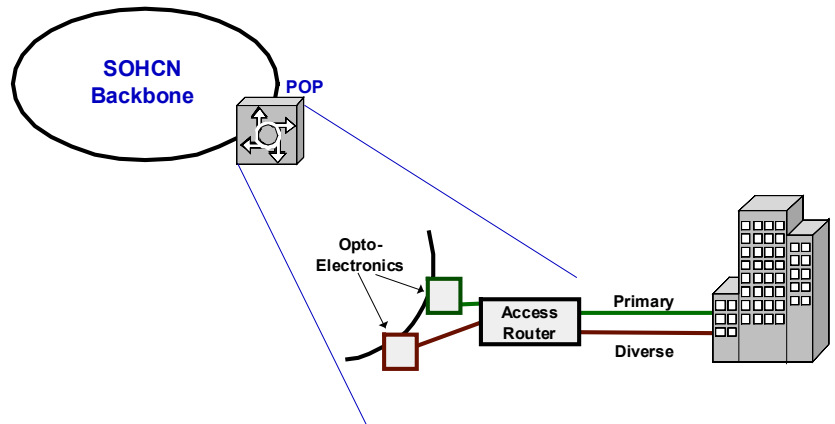

#### Example 3: Minimal Redundancy

In this example, a single chassis is used for opto-electronics and the access router. Internal redundancy within the chassis may exist.

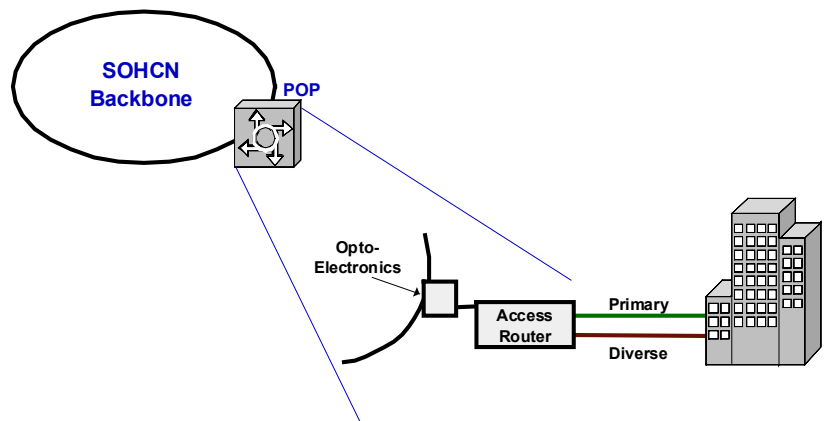

In reference to the three preceding examples of POP redundancy, Carriers are to:

1. Provide a diagram of equivalent or more detail illustrating the POP architecture for the proposed backbone to serve the SOHCN requirements.
2. Provide a verbal explanation of the POP diagram that includes:
  - Description of the types of redundancy
  - Explanation the opto-electronic fail-over in the event of fiber-cuts
  - Explanation of the operation of primary and diverse links from the POP to the SOHCN member function in normal and fail-over modes.
  - Explain how the costs for redundant connections are calculated. For instance, if a facility has a primary connection operating at 1 Gbps, explain how the cost of the redundant connection operating at 1 Gbps is calculated. Examples of possible answers include:
    - Same as the cost of the primary connection, effectively doubling the cost
    - Some percentage of the cost of the primary connection
    - Other way of calculating the cost

Carrier Response:

### 6.12. SOHCN POP Information **[Response Required]**

Complete a copy of the following template for each POP that will serve the SOHCN Backbone.

SOHCN POP Name	[Name of SOHCN POP]
SOHCN POP Identifier	[Abbreviated ID for the POP]
Street Address	
City	
State	
Zip	
Diverse Entry to SOHCN POP?	[Existing, Build]
Diverse Routes from SOHCN POP?	[Existing, Build]
Neighboring SOHCN POP (1)	[SOHCN POP Identifier]
Neighboring SOHCN POP (2)	[SOHCN POP Identifier]
Neighboring SOHCN POP (3)	[SOHCN POP Identifier]
Back-up Power	[Hours at Full Utilization]
Fire Protection	[Type and coverage]
Security	[Type]
Access Control	[Type]

#### Instructions

[Name of SOHCN POP] = the name you have assigned to the SOHCN POP in your proposed backbone plan.

[Abbreviated ID for the POP] = the ID you will use elsewhere in your response to identify this POP.

[Existing, Build] = reply with “Existing” if you already have the facilities needed, with “Build” if your response includes a commitment to build the necessary facilities.

Carrier Response: <b>&lt;Insert completed templates&gt;</b>
Carrier Narrative:

**6.13. Timeline [Response Required]**

Respondents must describe the timeline for establishing the proposed SOHCN Backbone, e.g. how many months from the time of award before all POPs are established, phases and related timelines, etc.

Carrier Response:
-------------------

## 7. Dedicated Bandwidth Specifications

### 7.1. Introduction [Informational]

In this section, we seek solutions that offer dedicated bandwidth solutions for the connectivity requirements of SOHCN Member sites to the serving SOHCN POP at speeds of 1.5 Mbps and above. While we list specific types of connections, this list is by no means intended to exclude other options. We are interested in any and all technology options.

If provided on a Layer 3 network, dedicated bandwidth connections must operate with mechanisms guaranteeing end-to-end operations at full port speed within the SOHCN.

If the dedicated bandwidth solution traverses a secondary Carrier network before connecting to the SOHCN Backbone, then the secondary Carrier network must be connected to at least two geographically dispersed SOHCN POPs using physically diverse fiber paths as pictured in the diagram above. Each of the redundant aggregate links to the SOHCN Backbone must be of sufficient capacity to provide 100% of the combined dedicated bandwidth SOHCN facility connections. Of course, this requires the Carrier to expand these aggregate links as SOHCN Members upgrade connection speeds to their facilities over the life of the contracts. The cost of the connectivity from the secondary Carrier network to the SOHCN Backbone must be included in the pricing for the individual facility connections.

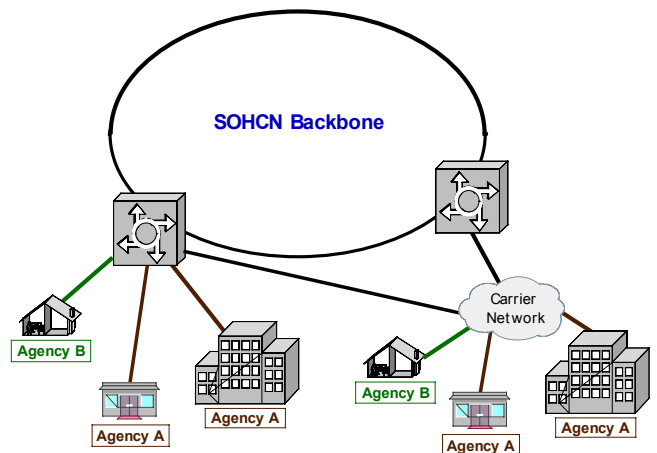

### 7.2. Examples of Dedicated Bandwidth Solutions [Informational]

The types of dedicated bandwidth interfaces envisioned include:

- Point-to-Point Metro-Ethernet
- Copper-Based Data Service
- Fiber-Based Data Services
- Traditional Leased Lines
- Direct Fiber-Optic Connections: Direct fiber-optic links offer the constituents the ability to drive the connection at whatever speed the equipment at both ends will accommodate. The Respondent must include the cost of fiber continuity maintenance in the monthly service costs.
- Carrier Alternates: Carrier alternates providing functionally equivalent services are also encouraged.

### 7.3. Service Offering Rate Table Response Template **[Response Required]**

For each type of dedicated bandwidth service you offer, complete a copy of the following rate table template. These rate tables do not include facility build costs. Facility build costs are requested in Section 12: Location-by-Location Availability and Facility Pricing.

#### Instructions:

Expand the template as needed, but make sure to include all of the elements below as a base.

The prices in the rate tables will serve as a price cap during the term of the MSA.

Service Name = what you have named the service you are offering.

Rate Table = a sequence number to identify this rate table from other rate tables you propose for different services or different geographic areas. This rate table information will be used later to provide pricing on a facility-by-facility basis.

Maximum Bit Error Rate = the guaranteed maximum error rate to be experienced using the Respondent's network.

Minimum Network Packet Delivery = the guaranteed minimum percentage of packets delivered end-to-end using the Respondent's network.

Maximum Latency = "not to exceed" average round-trip transmission time (in milliseconds) to/from any two SOHCN constituents.

Maximum Jitter = also known as *delay variation*, Jitter is defined as the variation or difference in the end-to-end delay between received packets of an IP or packet stream (in milliseconds) to/from any two SOHCN constituent sites.

Connection Pricing = the cost you are bidding for connecting facilities including the one-time costs other than facility charges (which are requested in Section 12 on a facility-by-facility basis). Note that the monthly charges you provide will hold steady as the "not to exceed" pricing for the connections across the term of the MSA.

Standard Rate Formula = the costs for these services based on your standard amortized rate schedule.

Capital Buy Down Formula = the costs for these services based on the SOHCN using FCC funds to buy down the upfront capital costs to reduce the ongoing monthly costs.

Upgrade Costs: Capital Buy Down on Initial Connection = the one-time cost for a facility to upgrade to a higher-speed connection when their initial connection was purchased under the Capital Buy Down Formula. Monthly costs governed by the Connection Pricing section of the rate table.

Upgrade Costs: Standard Rate on Initial Connection = the one-time cost for a facility to upgrade to a higher-speed connection when their initial connection was purchased under the Standard Rate Formula. Monthly costs governed by the Connection Pricing section of the rate table.

<b>Service Name</b>	[Name/Designation]				
Type	<b>Dedicated Bandwidth</b>				
Rate Table	[Number]				
<b>End-to-End Performance</b>					
Maximum Bit Error Rate	[in in "x" number of bits]				
Minimum Packet Delivery	[%]				
Maximum Latency	[Milliseconds]				
Maximum Jitter	[Milliseconds]				
<b>Connection Pricing</b> (do not include facility costs in this section)					
	<b>Standard Rate Formula</b>		<b>Capital Buy Down Formula</b>		
	Install	Monthly	Install+ Capital	Monthly	% Mo Reduction
<b>Speed of Connection</b>					
1.5 Mbps					
10 Mbps					
100 Mbps					
1 Gbps					
2.5 Gbps					
10 Gbps					
<b>Vendor Alternates</b>					
[Speed] [Units]					
[Speed] [Units]					
<b>One-Time Upgrade Costs: Capital Buy Down on initial connection</b>					
<b>Upgrade To</b>	10 Mbps	100 Mbps	1 Gbps	2.5 Gbps	10 Gbps
<b>Existing</b>					
1.5 Mbps					
10 Mbps					
100 Mbps					
1 Gbps					
2.5 Gbps					
10 Gbps					
<b>One-Time Upgrade Costs: Standard Rate on initial connection</b>					
<b>Upgrade To</b>	10 Mbps	100 Mbps	1 Gbps	2.5 Gbps	10 Gbps
<b>Existing</b>					
1.5 Mbps					
10 Mbps					
100 Mbps					
1 Gbps					
2.5 Gbps					
10 Gbps					

Carrier Response: <b>&lt;Insert completed templates&gt;</b>
Carrier Narrative:

## 8. Shared Bandwidth Solutions and Site Aggregation

### 8.1. Introduction [Response Required]

In this section, we seek solutions that offer shared bandwidth connectivity from the SOHCN Member sites to the serving SOHCN POP. While we list specific types of connections, this list is by no means intended to exclude other options. We are interested in any and all technology options.

If the shared bandwidth solution traverses a secondary Carrier network before connecting to the SOHCN Backbone, then the secondary Carrier network must be connected to at least two geographically dispersed SOHCN POPs using physically diverse fiber paths as pictured to the right. Each of the redundant aggregate links to the SOHCN Backbone must be of sufficient capacity to provide 200% of the combined CIR of the SOHCN facility connections served. Of course, this requires the Carrier to expand these aggregate links as SOHCN Members upgrade connection speeds to their facilities over the life of the contracts. The cost of the connectivity from the secondary Carrier network to the SOHCN Backbone must be included in the pricing for the individual facility connections.

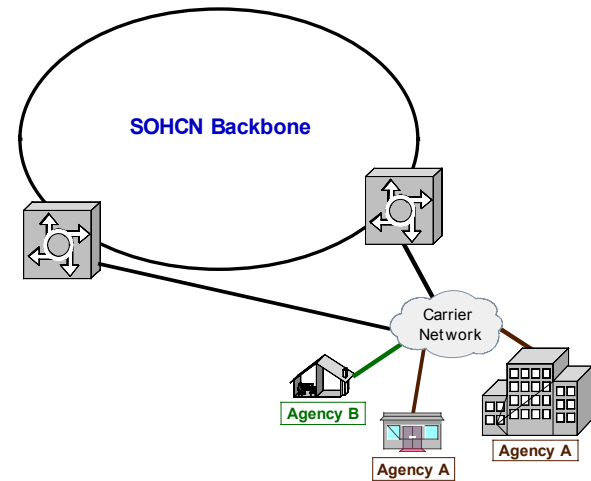

Carrier Response:

### 8.2. Examples of Shared Bandwidth Service Types [Response Required]

The types of shared bandwidth, last mile services envisioned include:

- Copper-Based Data Service
- Fiber-Based Data Services
- Shared Metro-Ethernet Connectivity
- MPLS/VPLS
- Carrier Alternates: Carrier alternates providing functionally equivalent services are also encouraged.

Carrier Response:

### 8.3. Service Offering Rate Table Response Template [Response Required]

For each type of shared bandwidth service you offer, complete a copy of the following rate table template. These rate tables do not include facility build costs. Facility build costs are requested in Section 12: Location-by-Location Availability and Facility Pricing.

Instructions:

Expand the template as needed, but make sure to include all of the elements below as a base.

The prices in the rate tables will serve as a price cap during the term of the MSA.

Service Name = what you have named the service you are offering.

Rate Table = a sequence number to identify this rate table from other rate tables you propose for different services or different geographic areas. This rate table information will be used later to provide pricing on a facility-by-facility basis.

Maximum Bit Error Rate = the guaranteed maximum error rate to be experienced using the Respondent's network.

Minimum Network Packet Delivery = the guaranteed minimum percentage of packets delivered end-to-end using the Respondent's network.

Maximum Latency = "not to exceed" average round-trip transmission time (in milliseconds) to/from any two SOHCN constituents.

Maximum Jitter = also known as *delay variation*, Jitter is defined as the variation or difference in the end-to-end delay between received packets of an IP or packet stream (in milliseconds) to/from any two SOHCN constituent sites.

Connection Pricing = the cost you are bidding for connecting facilities including the one-time costs other than facility charges (which are requested in Section 12 on a facility-by-facility basis). Note that the monthly charges you provide will hold steady as the "not to exceed" pricing for the connections across the term of the MSA.

Standard Rate Formula = the costs for these services based on your standard amortized rate schedule.

Capital Buy Down Formula = the costs for these services based on the SOHCN using FCC funds to buy down the upfront capital costs to reduce the ongoing monthly costs.

CIR Monthly Cost: CIR means the committed information rate for the connection to/from the constituent site to the SOHCN POP. This provides the minimum available end-to-end bandwidth on the connection during peak Respondent network utilization.

Upgrade Costs: Capital Buy Down on Initial Connection = the one-time cost for a facility to upgrade to a higher-speed connection when their initial connection was purchased under the Capital Buy Down Formula. Monthly costs governed by the Connection Pricing section of the rate table.

Upgrade Costs: Standard Rate on Initial Connection = the one-time cost for a facility to upgrade to a higher-speed connection when their initial connection was purchased under the Standard Rate Formula. Monthly costs governed by the Connection Pricing section of the rate table.

<b>Service Name</b>	[Name/Designation]
Type	<b>Shared Bandwidth</b>
Rate Table	[Number]

**End-to-End Performance**

Bit Error Rate	[in in "x" number of bits]
Minimum Packet Delivery	[%]
Maximum Latency	[Milliseconds]
Maximum Jitter	[Milliseconds]

**Connection Pricing (do not include facility costs in this section)**

	Standard Rate Formula		Capital Buy Down Formula		
	Install	Monthly	Install+ Capital	Monthly	% Mo Reduction
Speed of Connection					
1.5 Mbps					
10 Mbps					
100 Mbps					
500 Mbps					
1 Gbps					
Vendor Alternates					
[Speed] [Units]					

**CIR Monthly Cost**

	Standard Rate		Capital Buy Down Formula		
	Activation	Monthly	Install+ Capital	Monthly	*% Mo Reduction
Per each 1 Mbps					

**Upgrade Costs: Capital Buy Down on Initial Connection**

Upgrade To	10 Mbps	100 Mbps	500 Mbps	1 Gbps
<b>Existing</b>				
1.5 Mbps				
10 Mbps				
100 Mbps				
500 Mbps				
1 Gbps				

**Upgrade Costs: Standard Rate on Initial Connection**

Upgrade To	10 Mbps	100 Mbps	500 Mbps	1 Gbps
<b>Existing</b>				
1.5 Mbps				
10 Mbps				
100 Mbps				
500 Mbps				
1 Gbps				

Carrier Response: <b>&lt;Insert completed templates&gt;</b>
Carrier Narrative:

## 9. Interconnection to OARnet

### 9.1. Locations [Response Required]

To provide connectivity to urban medical facilities across the State, the SOHCN Backbone must be interconnected to the OARnet in at least two locations. OARnet operates several POPs in the Phase 1 service area:

- Athens OARnet POP
- Chillicothe OARnet POP
- Portsmouth OARnet POP
- Columbus OARnet POP (4 locations)

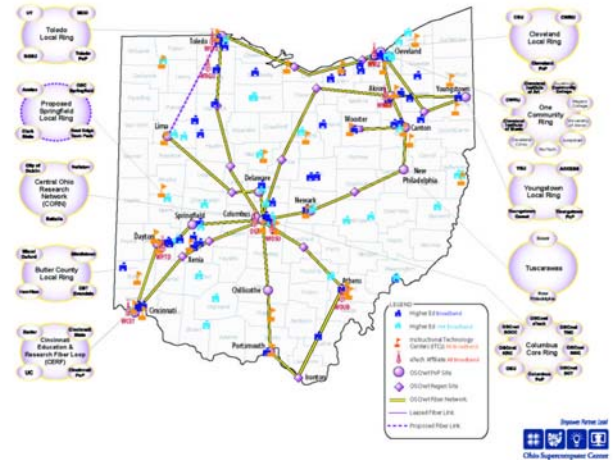

Addresses for the OARnet POPs are included in the Location-by-Location spreadsheet of Section 12.

Carrier Response:

### 9.2. Routing in Normal Condition [Response Required]

Explain how your proposed SOHCN Backbone would route traffic to/from the OARnet assuming that the SOHCN Backbone is connected to two OARnet POPs.

Carrier Response:

### 9.3. Routing During an Outage [Response Required]

Explain how your proposed SOHCN Backbone would re-route traffic should connectivity to one OARnet POP be lost due to either failure of the SOHCN connection or failure of the OARnet POP.

Carrier Response:

### 9.4. Service Offering Rate Table Response Template [Response Required]

For each type of dedicated bandwidth offering for connecting to OARnet you offer, complete a copy of the following rate table template. These rate tables do not include facility build costs. Facility build costs are requested in Section 12: Location-by-Location Availability and Facility Pricing.

Instructions:

Expand the template as needed, but make sure to include all of the elements below as a base.

The prices in the rate tables will serve as a price cap during the term of the MSA. .

Service Name = what you have named the service you are offering.

Rate Table = a sequence number to identify this rate table from other rate tables you propose for different services or different geographic areas. This rate table information will be used later to provide pricing on a facility-by-facility basis.

Maximum Bit Error Rate = the guaranteed maximum error rate to be experienced using the Respondent's network.

Minimum Network Packet Delivery = the guaranteed minimum percentage of packets delivered end-to-end using the Respondent's network.

Maximum Latency = "not to exceed" average round-trip transmission time (in milliseconds) between the constituent site and the OARnet POP location across the SOHCN network provided by the Respondent.

Maximum Jitter = also known as *delay variation*, Jitter is defined as the variation or difference in the end-to-end delay between received packets of an IP or packet stream (in milliseconds) from the constituent site to/from the OARnet POP location across the SOHCN network provided by the Respondent.

Connection Pricing = the cost you are bidding for connecting facilities including the one-time costs other than facility charges (which are requested in Section 12 on a facility-by-facility basis). Note that the monthly charges you provide will hold steady as the "not to exceed" pricing for the connections across the term of the MSA.

Standard Rate Formula = the costs for these services based on your standard amortized rate schedule.

Capital Buy Down Formula = the costs for these services based on the SOHCN using FCC funds to buy down the upfront capital costs to reduce the ongoing monthly costs.

Upgrade Costs: Capital Buy Down on Initial Connection = the one-time cost for a facility to upgrade to a higher-speed connection when their initial connection was purchased under the Capital Buy Down Formula. Monthly costs governed by the Connection Pricing section of the rate table.

Upgrade Costs: Standard Rate on Initial Connection = the one-time cost for a facility to upgrade to a higher-speed connection when their initial connection was purchased under the Standard Rate Formula. Monthly costs governed by the Connection Pricing section of the rate table.

<b>Service Name</b>	[Name/Designation]				
Type	<b>Dedicated Bandwidth to OARnet</b>				
Rate Table	[Number]				
<b>End-to-End Performance</b>					
Maximum Bit Error Rate	[in "x" number of bits]				
Minimum Packet Delivery	[%]				
Maximum Latency	[Milliseconds]				
Maximum Jitter	[Milliseconds]				
<b>Connection Pricing (do not include facility costs in this section)</b>					
	<b>Standard Rate Formula</b>		<b>Capital Buy Down Formula</b>		
	Install	Monthly	Install+ Capital	Monthly	% Mo Reduction
<b>Speed of Connection</b>					
1 Gbps					
2.5 Gbps					
10 Gbps					
40 Gbps					
<b>Vendor Alternates</b>					
[Speed] [Units]					
[Speed] [Units]					
<b>Upgrade Costs: Capital Buy Down on Initial Connection</b>					
<b>Upgrade To</b>	2.5 Gbps	10 Gbps	40 Gbps		
<b>Existing</b>					
1 Gbps					
2.5 Gbps					
10 Gbps					
40 Gbps					
<b>Upgrade Costs: Standard Rate on Initial Connection</b>					
<b>Upgrade To</b>	2.5 Gbps	10 Gbps	40 Gbps		
<b>Existing</b>					
1 Gbps					
2.5 Gbps					
10 Gbps					
40 Gbps					
Carrier Response: <b>&lt;Insert completed templates&gt;</b>					
Carrier Narrative:					

## 10. Internet Capacity

In addition to providing connectivity to facilities, we also request pricing for Internet capacity. The Internet capacity will be purchased by individual SOHCN Members to serve their facilities.

### 10.1. Quality of Internet Service [Response Required]

Describe the Internet connectivity you are offering, including, but not limited to:

- Breadth and capacity
- Network infrastructure
  - o Within the State of Ohio
  - o In neighboring states
  - o Within the continental United States
  - o Internationally

Carrier Response:
-------------------

### 10.2. Service Offering Rate Table Response Template [Response Required]

For each type of shared bandwidth service you offer complete a copy of the following rate table template.

#### Instructions:

Expand the template as needed, but make sure to include all of the elements below as a base.

The prices in the rate tables will serve as a price cap during the term of the MSA.

Given that Internet capacity is an optional add-on for facilities with an existing connection, no facility provisioning charges should be included.

Service Name = what you have named the service you are offering.

Rate Table = a sequence number to identify this rate table from other rate tables you propose for different services or different geographic areas. This rate table information will be used later to provide pricing on a facility-by-facility basis.

Network Availability = meaning that the Respondent's Egress port and related upstream network elements are in full working order and operating at full capacity.

Note: To achieve 99.99% availability, cumulative outages must not exceed four and four tenths (4.4) minutes per calendar month.

Maximum Bit Error Rate = the guaranteed maximum error rate to be experienced using the Respondent's network.

US Minimum Network Packet Delivery = the guaranteed minimum percentage of packets delivered end-to-end using the Respondent’s Internet capacity within the United States.

US Maximum Latency = “not to exceed” average round-trip transmission time (in milliseconds) using the Respondent’s Internet capacity within the United States

US Maximum Jitter = also known as *delay variation*, Jitter is defined as the variation or difference in the end-to-end delay between received packets of an IP or packet stream (in milliseconds) using the Respondent’s Internet capacity within the United States.

Global Minimum Network Packet Delivery = the guaranteed minimum percentage of packets delivered end-to-end using the Respondent’s Internet capacity worldwide.

Global Maximum Latency = “not to exceed” average round-trip transmission time (in milliseconds) using the Respondent’s Internet capacity worldwide.

Global Maximum Jitter = also known as *delay variation*, Jitter is defined as the variation or difference in the end-to-end delay between received packets of an IP or packet stream (in milliseconds) using the Respondent’s Internet capacity worldwide.

Standard Rate Formula = the costs for these services based on your standard amortized rate schedule.

Bandwidth Cost = the cost to add Internet capacity to an existing SOHCN connection on a per Mbps basis.

<b>Service Name</b>	[Name/Designation]	
Type	<b>Internet Capacity</b>	
Rate Table	[Number]	
<b>Availability and Performance</b>		
Internet Capacity Availability	[99.xxx%]	
Maximum Bit Error Rate	[in in "x" number of bits]	
US Minimum Packet Delivery	[%]	
US Maximum Latency	[Milliseconds]	
US Maximum Jitter	[Milliseconds]	
Global Minimum Packet Delivery	[%]	
Global Maximum Latency	[Milliseconds]	
Global Maximum Jitter	[Milliseconds]	
<b>Bandwidth Cost</b>		
	Standard Rate	
	Activation	Monthly
Per each 1 Mbps		

Carrier Response: <b>&lt;Insert completed templates&gt;</b>
Carrier Narrative:

## 11. Data Replication Links

As business continuity continues to grow as a concern for SOHCN Members, the need for data replication links also grows. Thus the SOHCN Members seek pricing for dedicated bandwidth data replication links. These connections are additive to whatever SOHCN connections the Member elects to install. Thus required facilities will already be in place.

### 11.1. Separate Bandwidth [Response Required]

The data replication links must provide bandwidth that does not impact the other SOHCN Member connectivity. In other words, the data replication links need to behave as dedicated point-to-point connections between the primary and back-up sites.

Carrier Response:

### 11.2. Network Solution for Data Replication Links [Response Required]

Explain your approach to providing data replication links, including, but not limited to:

1. Will the proposed data replication link run on the same Layer 2/3 network as the SOHCN Member connections?
2. The types of interfaces you can support on the proposed data replication links, e.g.
  - Fiber Channel
  - IP
  - DWDM

Carrier Response:

### 11.3. Initial Requirements [Response Required]

At the time of the release of this RFP, we are certain of the need for replication links between:

#### Pairing #1

Adena Regional Medical Center, Chillicothe, Facility ID 1001  
Adena Health Center, Waverly, Facility ID 1004

#### Pairing #2

Holzer Medical Center, Gallipolis, Facility ID 1050  
Holzer Medical Center, Jackson, Facility ID 1054

Carrier Response:

#### 11.4. Service Offering Rate Table Response Template [Response Required]

For each type of data replication link you offer, complete a copy of the following rate table template.

##### Instructions:

Expand the template as needed, but make sure to include all of the elements below as a base.

The prices in the rate tables will serve as a price cap during the term of the MSA.

Service Name = what you have named the service you are offering.

Rate Table = a sequence number to identify this rate table from other rate tables you propose for different services or different geographic areas. This rate table information will be used later to provide pricing on a facility-by-facility basis.

Maximum Bit Error Rate = the guaranteed maximum error rate to be experienced using the Respondent's network.

Minimum Network Packet Delivery = the guaranteed minimum percentage of packets delivered end-to-end using the Respondent's network.

Maximum Latency = "not to exceed" average round-trip transmission time (in milliseconds) between the two constituent sites across the Respondent's network.

Maximum Jitter = also known as *delay variation*, Jitter is defined as the variation or difference in the end-to-end delay between received packets of an IP or packet stream (in milliseconds) between the two constituent sites.

Connection Pricing = the cost you are bidding for connecting facilities including the one-time costs other than facility charges (which are requested in Section 12 on a facility-by-facility basis). Note that the monthly charges you provide will hold steady as the "not to exceed" pricing for the connections across the term of the MSA.

Standard Rate Formula = the costs for these services based on your standard amortized rate schedule.

Capital Buy Down Formula = the costs for these services based on the SOHCN using FCC funds to buy down the upfront capital costs to reduce the ongoing monthly costs.

Upgrade Costs: Capital Buy Down on Initial Connection = the one-time cost for a facility to upgrade to a higher-speed connection when their initial connection was purchased under the Capital Buy Down Formula. Monthly costs governed by the Connection Pricing section of the rate table.

Upgrade Costs: Standard Rate on Initial Connection = the one-time cost for a facility to upgrade to a higher-speed connection when their initial connection was purchased under the Standard Rate Formula. Monthly costs governed by the Connection Pricing section of the rate table.

<b>Service Name</b>	[Name/Designation]				
Type	<b>Data Replication Links</b>				
Rate Table	[Number]				
<b>End-to-End Performance</b>					
Maximum Bit Error Rate	[in "x" number of bits]				
Minimum Packet Delivery	[%]				
Maximum Latency	[Milliseconds]				
Maximum Jitter	[Milliseconds]				
<b>Connection Pricing (do not include facility costs in this section)</b>					
	<b>Standard Rate Formula</b>		<b>Capital Buy Down Formula</b>		
	Install	Monthly	Install+ Capital	Monthly	% Mo Reduction
<b>Speed of Connection</b>					
1 Gbps					
2.5 Gbps					
10 Gbps					
40 Gbps					
<b>Vendor Alternates</b>					
[Speed] [Units]					
[Speed] [Units]					
<b>One-Time Upgrade Costs: Capital Buy Down on Initial Connection</b>					
<b>Upgrade To</b>	2.5 Gbps	10 Gbps	40 Gbps		
<b>Existing</b>					
1 Gbps					
2.5 Gbps					
10 Gbps					
40 Gbps					
<b>One-Time Upgrade Costs: Standard Rate on Initial Connection</b>					
<b>Upgrade To</b>	2.5 Gbps	10 Gbps	40 Gbps		
<b>Existing</b>					
1 Gbps					
2.5 Gbps					
10 Gbps					
40 Gbps					

Carrier Response: <b>&lt;Insert completed templates&gt;</b>
Carrier Narrative:

## 12. Location-by-Location Availability and Facility Pricing [Response Required]

In the following pages, we seek information and pricing on a location-by-location basis for the:

- Status and provisioning cost for carrier's primary entry to facility
- Status and provisioning cost for carrier's diverse entry to facility and diverse route to serving Carrier SOH{CN POP.
- Availability of dedicated and shared services with applicable rate tables
- Identity of carriers contributing to the connection

All SOHCN facilities and the OARnet POP locations are included in the tables in the accompanying Excel spreadsheet. After completing the tables, **Respondents are required to paste the completed tables into the body of the response document and to provide the tables in Excel format as well.**

### Instructions:

Category of Facility = [1, 2, 3, 4] = As defined in Section 4.4

Pricing for Diverse Entry is only requested for Class 1 and Class 2 facilities (as defined in Section 4.4.

[Yes, Build] = "Yes" means that the facilities are already in place, "Build" means that your pricing includes the commitment to build the required facilities.

Diversity Method = [A, B, C, Other] = The method of providing diverse connectivity as explained in Section 4.5. If Carrier responds with "Other" then the method must be clearly describes in response to section 4.5.

[Dollar Amount] = Respondent's price for the facility.

[Yes, No] = Respondent's indication whether the class of service is offered at the specific facility.

[Rate Table Number(s)] = Respondent indicates which rate tables defined in sections 7.3. and 8.3. apply at this location.

[Carrier ID(s)] = IDs of Carriers, as defined in section 5.7. that are contributing to the connection to this facility.

<b>SOHCN Entity</b>	[Name or Organization]
<b>SOHCN Facility</b>	[Name of Facility]
<b>SOHCN Facility ID</b>	[SOHCN Facility ID]
Address City/State NPA-nxx Category of Facility	[1, 2, 3, 4]
Primary Entry? Number of Fiber Strands Number of Copper Conductors Provisioning Cost-Primary	[Yes, Build] [Quantity] [Quantity] [Dollar Amount]
Diverse Entry? Number of Fiber Strands Number of Copper Conductors Diverse Route to POP? Diversity Method Provisioning Cost-Diverse	[Yes, Build] [Quantity] [Quantity] [Yes, Build] [A, B, C, Other] [Dollar Amount]
<b>Dedicated Services?</b> Rate Table(s) Carrier(s) Providing	[Yes, No] [Rate Table Number(s)] [Carrier ID(s)]
<b>Shared Services?</b> Rate Table(s) Carrier(s) Providing	[Yes, No] [Rate Table Number(s)] [Carrier ID(s)]

Carrier Response: <b>&lt;Insert completed templates for SOHCN and OSCnet&gt;</b>
Carrier Response:

## 13. Community Broadband Expansion

In addition to the specific facility connections included in the RFP, we are also adamant about the need for expanded broadband access in the communities in Southern Ohio.

The reasons are simple:

- a. Physician homes have emerged as a critical target for broadband deployment, providing essential after-hours coverage for rural facilities.
- b. The quality and efficiency of in-home patient care can be significantly improved by using technologies that rely on residential broadband connectivity.
- c. The financial strength of the rural health care providers depends on the overall economic well being of the region. Broadband for small business and residential customers provides an essential ingredient for economic growth.
- d. Widespread broadband adoption across the region will improve the sustainability of health care broadband through the economies of scale.

Of course, the FCC funds cannot be used for community broadband initiatives. However, due to the investment in network infrastructure required to serve the SOHCN Member facilities, we anticipate the ability of Respondents to expand general availability of broadband services.

### 13.1. Towns Hosting SOHCN Member Facilities [Informational]

At a minimum, we expect the network improvements made to fulfill the SOHCN mission to benefit the towns hosting the SOHCN facilities. As the anchor tenants for bringing broadband enhancements to the town, we seek specific Respondent commitments for expanding services in these towns.

### 13.2. Other Towns and the Rural Expanses [Informational]

In addition, as Respondents design the network for supporting the SOHCN requirements, we encourage the Carriers to make provisions for expanded broadband services across the SOHCN service region. For instance, a small town in the path of a fiber build would benefit greatly if the Carrier established a POP and offered last mile connectivity to small business and residents in the town. As another example, a cluster of homes along a fiber route might be a target for a wireless extension of the Carrier's broadband network.

### 13.3. No Cross-Subsidy [Response Required]

Respondents must guarantee that the FCC funding will not subsidize the Community Broadband Expansion. Rather, we anticipate the Carrier's ability to expand services because of the SOHCN Member facilities serving as anchor tenants. The FCC issues specific written guidance on this issue in March 2009 as a FAQ on the agency website at: <http://www.fcc.gov/cgb/rural/rhcp.html#faq23>

The relevant FCC FAQ reads as follows:

*"In selecting a vendor, may a participant consider the vendor's commitment to provide excess capacity for community use?"*

- *Yes, as long as USF funds are not used to pay for the excess capacity and there is no increase in the cost for the dedicated network facilities.*
- *The Pilot Program will fund up to 85% of the costs incurred to deploy a state or regional dedicated broadband health care network. Only eligible health care providers and consortia that include eligible health care providers may apply for and receive funding. Ineligible entities are prohibited from receiving any funding from the Pilot Program. A selected participant is not restricted from sharing a network with ineligible entities, but the ineligible entities must pay their fair share of network costs attributable to the portion of network capacity used. See 2007 RHC PP Selection Order, paras. 16-19, 47, 73, 107. For these reasons, a participant must be able to demonstrate that a vendor's provision of excess capacity for community use will not increase the cost of the dedicated broadband health care network.*
- *As part of the competitive bidding requirements, participants must certify to USAC that the vendor it chooses is, to the best of the participant's knowledge, the most cost-effective service or facility provider available. The Commission has defined "cost-effective" as "the method that costs the least after consideration of the features, quality of transmission, reliability, and other factors that the health care provider deems relevant to . . . choosing a method of providing the required health care services." While participants must make price a primary factor it does not have to be the sole primary factor. As detailed in paragraphs 78 and 79 of the 2007 RHC PP Selection Order, participants are required to consider non-cost evaluation factors. Accordingly, if a participant is either required under its applicable procurement rules or chooses to consider factors or assign points related to a vendor's commitment to provide excess capacity for community use, it may do so, as long as the selected vendor is the most cost-effective.*
- *If a vendor only pays the incremental costs for excess capacity facilities built on the vendors own initiative or at the request of the participant, ownership of such facilities must be retained by participant and eligible HCP entities (because the bulk of the costs are USF funded). In contrast, if the vendor pays fair share for the excess capacity facilities, it may retain ownership and/or sell the excess capacity to future customers.*
- *The following must be considered when including excess capacity for community use as a factor in selecting a vendor:*
  - *Participant must demonstrate that USF funds will not be used to pay for such excess capacity.*
  - *The vendor must show that the costs for such excess capacity did not increase the eligible costs for the dedicated health care network.*
  - *Participants must receive sufficient cost information to be able to determine costs for the excess capacity apart from the costs for the dedicated health care network, and should seek assurances from vendors that the bid cost and quality of service for dedicated broadband health care network is the same whether the excess capacity for community use is included or not.*
  - *Participants should clarify in their RFPs that responses to the RFP that do not have commitments for excess capacity for community use, will also be considered."*

The most salient summary of the FAQ is in the final section starting with: *"The following must be considered when including excess capacity..."*

Respondent must explain and substantiate how the proposed community broadband services will be offered without any cross-subsidization with the FCC funds in consideration of the terms and conditions of the FCC FAQ above. Such explanation can be in conjunction with rate formulas required in sections 14.16 and 14.17.

Carrier Response:

### 13.4. Service Area Maps **[Response Required]**

In addition to completing the templates in this section, also provide maps of the proposed community broadband service areas.

Carrier Response:

### 13.5. Community Broadband Service Offerings **[Response Required]**

In the following pages, Respondents will complete the charts to indicate the services to be offered broadly to the community in the SOHCN service area. We have provided tables for each of the towns hosting a SOHCN facility in the accompanying Excel spreadsheet. We also provide a blank template that you can copy as many times as necessary to provide responses for additional service areas. After completing the tables, **Respondents are required to paste the completed tables into the body of the response document and to provide the tables in Excel format as well.**

#### Instructions:

Service Area = the [Town/Area Designation] you assign to a geographic service area.

Geographic Boundary Points = the Respondent's method of defining the applicable service area.

[Address or Geocode] = method used to define a geographic area. Respondent can provide:

- Address points that define the border of a service area.
- Geocode information can be as simple as a ZIP code or as detailed as latitude/longitude coordinates defining boundary points for a service area.

[Yes, No] = Respondent's indication whether the class of service is offered at the specific facility.

[Rate Table Number(s)] = Respondent indicates which rate tables defined in sections 7.3. and 8.3. apply at this location.

Percentage of Addresses Serviceable = the percentage of addresses within the Service Area to which the Respondent guarantees that services can be provided if ordered.

<b>Service Area</b>	[Town/Area Designation]
Size of Area	[Area in Square Miles]
Increase over Existing Service Area	[Area in Square Miles]
Geographic Boundary Points	
Point A	[Address or Geocode]
Point B	[Address or Geocode]
Point C	[Address or Geocode]
Point D	[Address or Geocode]
Point E	[Address or Geocode]
Point F	[Address or Geocode]
Point G	[Address or Geocode]
<b>Dedicated Services?</b>	[Yes, No]
Rate Table(s)	[Rate Table Number]
Percentage of Addresses Servicable	[%]
<b>Shared Services?</b>	[Yes, No]
Rate Table(s)	[Rate Table Number]
Percentage of Addresses Serviceable	[%]

Carrier Response: <b>&lt;Insert completed templates&gt;</b>
Carrier Narrative:

## 14. Other Terms and Conditions

### 14.1. Ordering and Provisioning Timeline [Response Required]

The following table focuses on key stages in the ordering and provisioning process. Respondents are to reply with “not to exceed” business day intervals. Respondents must provide contractually meaningful “not to exceed” timelines in the following table.

Stage	Respondent Commitment
Confirm order receipt	One (1) Business Day
Firm order commitment, with due date	
Provide progress updates every	
Maximum total interval without plant build	
Maximum total interval with plant build	

Carrier Narrative:
--------------------

### 14.2. Ordering and Provisioning Communications [Response Required]

Describe the methods of notification to the SOHCN Member for the stages defined in the preceding table.

Carrier Response:
-------------------

### 14.3. Non-Recurring Charges: Installation Charges and Capital Buy Down Costs [Response Required]

#### Eligible Entities/Facilities

The invoices for non-recurring costs, including installation charges and capital buy down costs for eligible facilities, have to flow through the SOHCN in order to qualify for the FCC funding. For each connection, 100% of the non-recurring costs must be invoiced on a single bill. For these non-recurring costs for eligible facilities, a minimum of 15% will be paid by the SOHCN and up to 85% will be paid by the FCC directly to the Carrier. Respondents are to refer to the FCC and USAC websites for details on how payment will be received. Any monthly recurring costs on the first invoice will be paid by the SOHCN Member directly to the Carrier.

#### Ineligible Entities/Facilities

Carrier invoices must be submitted directly to Ineligible entities. These entities will be responsible for 100% of the costs for their connections. We encourage the Carriers to make the capital buy down option available to ineligible entities.

Carrier Response:
-------------------

**14.4. Monthly Recurring Costs for All SOHCN Connections [Response Required]**

After the initial invoice for a given connection, the Carrier must bill the SOHCN Member directly for monthly recurring costs. The SOHCN Member will be responsible for 100% of the monthly recurring costs.

Carrier Response:

**14.5. Charges After Disconnect [Response Required]**

Once a disconnect order has been issued by the SOHCN Member and accepted by the Carrier, the Carrier must not hold the SOHCN Member responsible for any circuit or service charges after the requested disconnect due date, regardless of whether the Carrier has actually worked the disconnect. The SOHCN Member will adhere to established time intervals for service disconnect orders, as defined in the MSA.

Carrier Response:

**14.6. No Charge Quotes [Response Required]**

Carrier must provide quotes for services at no charge to the SOHCN Members, regardless of whether the SOHCN Member places an order for that service.

Carrier Response:

**14.7. Tax Exemption [Response Required]**

Most of the SOHCN Members are exempt from all excise taxes: federal, state and local, and from state sales taxes. Carriers must not include such taxes in any invoices resulting from the contract(s) arising from this RFP. The SOHCN Member list includes indication of tax-exempt status. Upon request, SOHCN Members shall furnish Carriers with tax exemption statements.

Carrier Response:

**14.8. Other Taxes, Fees and Surcharges [Response Required]**

Carrier must not bill for any taxes, fees or surcharges without identifying the tax, fee or surcharge and showing why it is legally chargeable to the SOHCN Members. If it is determined that taxes, fees and/or surcharges are legally chargeable to a SOHCN Member, the SOHCN Member will pay the tax, fee and/or surcharge, as required.

Carrier Response:

**14.9. Termination [Response Required]**

1. The MSA and/or related contracts may be terminated at any time by mutual consent of the parties.
2. The MSA and/or related contract may be terminated due to Carrier's material failure to perform, persistent non-compliance or other types of breach of the terms and conditions of the MSA and/or contract. The SOHCN Inc. or SOHCN Member will provide written notice to Carrier at least 60 days prior to the termination date. This written notice shall state the reasons for termination. Carrier shall be allowed 30 days from the date the written notice was mailed to remedy the conditions outlined in the notice to the SOHCN Inc.'s or the SOHCN Member's satisfaction.

Carrier Response:

**14.10. Amendments to the MSA [Response Required]**

1. The MSA may be amended at any time by mutual consent of the parties.
2. Any amendment or change order must be in writing and signed by authorized representatives of both the Carrier and the SOHCN Inc.
3. Respondent shall specify in writing to the SOHCN Inc. the name(s) of the person(s) authorized to sign contract amendments.
4. Only Marcus Bost, President of the SOHCN Inc. Board, and/or his authorized (in writing) designee may authorize amendments to the MSA.

Carrier Response:

**14.11. Assignments [Response Required]**

The Carrier shall not assign the whole or any part of the contracts or any moneys due or to become due hereunder without written consent of the SOHCN Inc. or the respective SOHCN Member. In case the bidder assigns all or any part of any moneys due or to become due under the MSA or resulting contracts, the instrument of assignment shall contain a clause substantially to the effect that it is agreed that the right of the assignee in and to any moneys due or to become due to the Carrier shall be subject to prior claims of all persons, firms and corporations for services rendered or materials supplied for the performance of the work called for in the contract.

Carrier Response:

**14.12. Subcontracting [Response Required]**

1. The Carrier may utilize the services of specialty Subcontractors on those parts of the work which, under normal contracting practices, are performed by specialty Subcontractors.
3. The Carrier shall be as fully responsible to the SOHCN Inc. and/or the SOHCN Member for the acts and omissions of all Subcontractors, and of persons either directly or indirectly employed by them, as the bidder is responsible for the acts and omissions of persons directly employed by said bidder.
4. The Carrier shall cause appropriate provisions to be inserted in all subcontracts relative to the work to bind Subcontractors to the bidder by the terms of the MSA insofar as applicable to the work of Subcontractors and to give the bidder the same power as regards terminating any subcontract that the SOHCN Inc. and the SOHCN Members may exercise over the bidder, under any provisions of the MSA.
5. No action by the Carrier shall create any contractual relation between any Subcontractor and the SOHCN Inc. or the SOHCN Members.

Carrier Response:

**14.13. Applicable Laws, Regulations and Industry Standards [Response Required]**

1. Carrier and authorized subcontractors shall, at all times and in all respects, meet or exceed specifications for this type of network as stipulated by the manufacturer(s), by the industry at large, by applicable regulatory agencies and organizations, and by Southern Ohio Health Care Network.
2. Carrier shall be responsible for complying with all applicable state and local laws and ordinances in its performance of this contract.
3. Carrier shall comply with all applicable Federal Communications Commission and Public Utilities Commission of Ohio regulations.
4. The Carrier will certify that all equipment and installation be in compliance with the Federal Communications Commission (FCC) regulations, the State of Ohio electrical codes and national electrical codes. The Carrier will warrant that all installation of equipment is in full compliance with State of Ohio building codes, local and state fire codes, NFPA specifications, Underwriters Laboratories (UL) specifications, and any other established codes governing such installations.

Carrier Response:

#### **14.14. Project Management [Response Required]**

1. Southern Ohio Health Care Network will name a project manager for the implementation of this contract. The SOHCN project manager will be the point of contact with the bidder's project manager in all areas indicated in this Request for Proposals section. S/he will be empowered to resolve disputes and make decisions about any changes to the implementation plan or technical aspects of the system.
2. Carrier must also name a project manager who is employed directly by the company to whom the contract is awarded. This person must be empowered to authorize changes that impact the budget for the project. S/he must also carry out all the responsibilities noted in this Request for Proposals, such as scheduling, supervision, inspection, and status reporting.
3. Carrier project manager will carry a pager with nationwide range. The carrier project manager will respond to pages from the SOHCN project manager within two hours.
4. Status reports will be given verbally at the end of each working week to the SOHCN project manager. These status reports will recap work done during the week, preview the next week's tasks, and bring to our attention anything that may cause a delay in completing implementation as planned. Whenever requested by the SOHCN project manager, status reports in writing will be submitted.

Carrier Response:

#### **14.15. Closing Trouble Tickets [Response Required]**

Prior to closing trouble tickets, Carrier must receive confirmation from the SOHCN Member that all components related to trouble have been resolved.

Carrier Response:

#### **14.16. One-Time Non-Recurring Cost Formulas [Response Required]**

The SOHCN requires submission of contractually meaningful pricing formulas that detail all elements of proposed connections affecting one-time non-recurring costs. This must include any and all surcharges, taxes, third party costs and other incidental cost elements. The SOHCN must be able to accurately and fully determine the non-recurring cost for a given circuit by applying the formulas provided. During the term of the resulting master contracts, Respondent may lower, but cannot increase, the prices provided in the formulas. Further, the Respondent cannot add additional rate elements to the formulas during the term of the MSA.

Carrier Response:

**14.17. One-Time Non-Recurring Cost Formulas [Response Required]**

The SOHCN requires submission of contractually meaningful pricing formulas that detail all elements of proposed connections affecting monthly recurring costs. This must include any and all surcharges, taxes, third party costs and other incidental cost elements. The SOHCN must be able to accurately and fully determine the monthly recurring cost for a given circuit by applying the formulas provided. During the term of the resulting master contracts, Respondent may lower, but cannot increase, the prices provided in the formulas. Further, the Respondent cannot add additional rate elements to the formulas during the term of the MSA.

Carrier Response:

**14.18. Account Team Roster and Escalation Path [Response Required]**

Respondents must routinely provide to the SOHCN an up-to-date account team roster that provides a minimum of three (3) levels of escalation. The Respondent bears the responsibility of updating the roster prior to the occurrence of personnel changes that affect the direct account team and/or the escalation path. The minimum required data elements are shown in 14.18.

Carrier Response:

**14.19. Initial Account Team Roster [Response Required]**

Complete the following account team roster describing all account team members and providing a minimum of three (3) levels of management escalation. Expand the table as needed.

Name	Title	Office Phone	Mobile Phone	E-Mail

Carrier Narrative:

## 15. Related Equipment and Professional Services

The SOHCN Members desire an efficient mechanism to purchase equipment related to the services bid in the RFP. Exercise of the resulting purchasing mechanism will most likely occur at the same time that orders are being placed for the services.

### 15.1. Equipment Offering [Response Required]

List all associated manufacturers whose equipment the Carrier will make available for purchase by the SOHCN Members related to this RFP. Provide equipment discount schedules that will enable the SOHCN Member to purchase via the schedules on an on-going basis, at any time during the awarded contract period.

Given the changing marketplace and the evolution of technology, the SOHCN Members would like the ability, during the term of the contract, to review new and enhanced equipment offered by the Carrier. Likewise, the SOHCN Members also want to take advantage of the ongoing improvements in the price-performance curve to bring prices down. Thus on an annual basis, Respondents will have the opportunity to present the SOHCN Members with an updated list of eligible equipment, prices and discount schedules.

Carrier Response:

### 15.2. Maintenance [Response Required]

- Describe how equipment maintenance is offered and managed.
- Maintenance discount schedules will be required.

Carrier Response:

### 15.3. Warranties [Response Required]

- Describe the equipment warranty.

Carrier Response:

#### 15.4. Professional Services [Response Required]

The SOHCN Members desire an efficient mechanism to purchase professional services related to the services bid in this RFP. Exercise of the resulting purchasing mechanism will most likely occur at the same time that orders are being placed for the services.

- The SOHCN Members would like the ability to purchase professional services on an as-needed basis. Professional service(s) may include, but is not limited to: project management, technical support, system testing, etc.
- Carriers shall describe their ability to provide subject matter experts on related disciplines. Provide the level of expertise of resources that provide professional services.
- *Professional Services Rates.* Any Professional Services requested by SOHCN and agreed to and rendered by Carriers on a time-and-materials basis shall be provided at the service rates ("**Professional Services Rates**") set forth in the resulting contract.

Carrier Response:

## 16. Evaluation Matrices and Contract Awards

[Informational]

Responses will be evaluated by a Southern Ohio Health Care Network evaluation team using the scoring matrix below.

RFP Section	Points
3 Key Contractual Relationships	150
5 Respondent Qualifications	200
6 Proposed SOHCN Backbone	200
7 Dedicated Bandwidth Specifications	150
8 Shared Bandwidth Solutions and Site Aggregation	150
9 Interconnection with OARnet	100
10 Internet Capacity	50
11 Data Replication Links	100
12 Facility-by-Facility Availability	200
13 Community Broadband Expansion	200
14 Other Terms and Conditions	100
15 Related Equipment and Professional Services	-
Pricing	400
<b>Total</b>	<b>2,000</b>

**SOHCN Dedicated Bandwidth Response Template**

<b>Service Name</b>	[Name/Designation]				
Type	<b>Dedicated Bandwidth</b>				
Rate Table	[Number]				
<b>End-to-End Performance</b>					
Maximum Bit Error Rate	[in in "x" number of bits]				
Minimum Packet Delivery	[%]				
Maximum Latency	[Milliseconds]				
Maximum Jitter	[Milliseconds]				
<b>Connection Pricing (do not include facility costs in this section)</b>					
	<b>Standard Rate Formula</b>		<b>Capital Buy Down Formula</b>		
	Install	Monthly	Install+ Capital	Monthly	*% Mo Reduction
Speed of Connection					
1.5 Mbps					
10 Mbps					
100 Mbps					
1 Gbps					
2.5 Gbps					
10 Gbps					
Vendor Alternates					
[Speed] [Units]					
[Speed] [Units]					
<b>One-Time Upgrade Costs: Capital Buy Down on Initial Connection</b>					
<b>Upgrade</b>	10 Mbps	100 Mbps	1 Gbps	2.5 Gbps	10 Gbps
<b>Existing</b>					
1.5 Mbps					
10 Mbps					
100 Mbps					
1 Gbps					
2.5 Gbps					
10 Gbps					
<b>One-Time Upgrade Costs: Standard Rate on Initial Connection</b>					
<b>Upgrade</b>	10 Mbps	100 Mbps	1 Gbps	2.5 Gbps	10 Gbps
<b>Existing</b>					
1.5 Mbps					
10 Mbps					
100 Mbps					
1 Gbps					
2.5 Gbps					
10 Gbps					

**SOHCN Shared Bandwidth Response Template**

<b>Service Name</b>	[Name/Designation]				
Type	<b>Shared Bandwidth</b>				
Rate Table	[Number]				
<b>End-to-End Performance</b>					
Maximum Bit Error Rate	[in in "x" number of bits]				
Minimum Packet Delivery	[%]				
Maximum Latency	[Milliseconds]				
Maximum Jitter	[Milliseconds]				
<b>Connection Pricing</b> (do not include facility costs in this section)					
	Standard Rate Formula		Capital Buy Down Formula		
	Install	Monthly	Install+ Capital	Monthly	*% Mo Reduction
Speed of Connection					
1.5 Mbps					
10 Mbps					
100 Mbps					
500 Mbps					
1 Gbps					
Vendor Alternates					
[Speed] [Units]					
<b>CIR Monthly Cost</b>					
	Standard Rate		Capital Buy Down Formula		
	Activation	Monthly	Install+ Capital	Monthly	*% Mo Reduction
Per each 1 Mbps					
<b>Upgrade Costs: Capital Buy Down on Initial Connection</b>					
<b>Upgrade</b>	10 Mbps	100 Mbps	500 Mbps	1 Gbps	
<b>Existing</b>					
1.5 Mbps					
10 Mbps					
100 Mbps					
500 Mbps					
1 Gbps					
<b>Upgrade Costs: Standard Rate on Initial Connection</b>					
<b>Upgrade</b>	10 Mbps	100 Mbps	500 Mbps	1 Gbps	
<b>Existing</b>					
1.5 Mbps					
10 Mbps					
100 Mbps					
500 Mbps					
1 Gbps					

**SOHCN Dedicated Bandwidth to OSCnet Response Template**

<b>Service Name</b>	[Name/Designation]				
Type	<b>Dedicated Bandwidth to OSCnet</b>				
Rate Table	[Number]				
<b>End-to-End Performance</b>					
Maximum Bit Error Rate	[in in "x" number of bits]				
Minimum Packet Delivery	[%]				
Maximum Latency	[Milliseconds]				
Maximum Jitter	[Milliseconds]				
<b>Connection Pricing</b> (do not include facility costs in this section)					
	Standard Rate Formula		Capital Buy Down Formula		
	Install	Monthly	Install+ Capital	Monthly	*% Mo Reduction
Speed of Connection					
1 Gbps					
2.5 Gbps					
10 Gbps					
40 Gbps					
Vendor Alternates					
[Speed] [Units]					
[Speed] [Units]					
<b>Upgrade Costs: Capital Buy Down on Initial Connection</b>					
<b>Upgrade</b>	2.5 Gbps	10 Gbps	40 Gbps		
<b>Existing</b>					
1 Gbps					
2.5 Gbps					
10 Gbps					
40 Gbps					
<b>Upgrade Costs: Standard Rate on Initial Connection</b>					
<b>Upgrade</b>	2.5 Gbps	10 Gbps	40 Gbps		
<b>Existing</b>					
1 Gbps					
2.5 Gbps					
10 Gbps					
40 Gbps					

### SOHCN Internet Capacity Rate Template

<b>Service Name</b>	[Name/Designation]	
Type	<b>Internet Capacity</b>	
Rate Table	[Number]	
<b>Availability and Performance</b>		
Internet Capacity Availability	[99.xxx%]	
Maximum Bit Error Rate	[in in "x" number of bits]	
US Minimum Packet Delivery	[%]	
US Maximum Latency	[Milliseconds]	
US Maximum Jitter	[Milliseconds]	
Global Minimum Packet Delivery	[%]	
Global Maximum Latency	[Milliseconds]	
Global Maximum Jitter	[Milliseconds]	
<b>Bandwidth Cost</b>		
	Standard Rate	
	Activation	Monthly
Per each 1 Mbps		

**SOHCN Data Replication Links Response Template**

<b>Service Name</b>	[Name/Designation]				
Type	<b>Data Replication Links</b>				
Rate Table	[Number]				
<b>End-to-End Performance</b>					
Maximum Bit Error Rate	[in in "x" number of bits]				
Minimum Packet Delivery	[%]				
Maximum Latency	[Milliseconds]				
Maximum Jitter	[Milliseconds]				
<b>Connection Pricing (do not include facility costs in this section)</b>					
	Standard Rate Formula		Capital Buy Down Formula		
	Install	Monthly	Install+ Capital	Monthly	*% Mo Reduction
Speed of Connection					
1 Gbps					
2.5 Gbps					
10 Gbps					
40 Gbps					
Vendor Alternates					
[Speed] [Units]					
[Speed] [Units]					
<b>Upgrade Costs: Capital Buy Down on Initial Connection</b>					
<b>Upgrade</b>	2.5 Gbps	10 Gbps	40 Gbps		
<b>Existing</b>					
1 Gbps					
2.5 Gbps					
10 Gbps					
40 Gbps					
<b>Upgrade Costs: Standard Rate on Initial Connection</b>					
<b>Upgrade</b>	2.5 Gbps	10 Gbps	40 Gbps		
<b>Existing</b>					
1 Gbps					
2.5 Gbps					
10 Gbps					
40 Gbps					

**SOHCN Facility Response Tables**

<b>SOHCN Entity</b>	Adena Health System	Adena Health System	Adena Health System
<b>SOHCN Facility</b>	Regional Medical Center	Urgent Care	Home Care Services
<b>SOHCN Facility ID</b>	1001	1002	1003
Address	272 Hospital Road	1000 Veterans Dr.	111 West Water St.
City/State	Chillicothe, OH	Jackson, OH	Chillicothe, OH
NPA-nxx	740-779	740-395	740-779
Class of Facility	1	2	3
Primary Entry?	[Yes, Build]	[Yes, Build]	[Yes, Build]
Number of Fiber Strands	[Quantity]	[Quantity]	[Quantity]
Number of Copper Conductors	[Quantity]	[Quantity]	[Quantity]
Provisioning Cost-Primary	[Dollar Amount]	[Dollar Amount]	[Dollar Amount]
Diverse Entry?	[Yes, Build]	[Yes, Build]	[Yes, Build]
Number of Fiber Strands	[Quantity]	[Quantity]	[Quantity]
Number of Copper Conductors	[Quantity]	[Quantity]	[Quantity]
Diverse Route to POP?	[Yes, Build]	[Yes, Build]	[Yes, Build]
Diversity Method	[A, B, C, Other]	[A, B, C, Other]	[A, B, C, Other]
Provisioning Cost-Diverse	[Dollar Amount]	[Dollar Amount]	[Dollar Amount]
<b>Dedicated Services?</b>	[Yes, No]	[Yes, No]	[Yes, No]
Rate Table(s)	Rate Table Number(s)	Rate Table Number(s)	Rate Table Number(s)
Carrier(s) Providing	[Carrier ID(s)]	[Carrier ID(s)]	[Carrier ID(s)]
<b>Shared Services?</b>	[Yes, No]	[Yes, No]	[Yes, No]
Rate Table(s)	Rate Table Number(s)	Rate Table Number(s)	Rate Table Number(s)
Carrier(s) Providing	[Carrier ID(s)]	[Carrier ID(s)]	[Carrier ID(s)]

### SOHCN Facility Response Tables

SOHCN Entity	Adena Health System	Adena Health System	Adena Health System
SOHCN Facility	Urgent Care	Greenfield Area Medical Center	Counseling Center
SOHCN Facility ID	1004	1005	1006
Address	12340 SR 104	550 Mirabeau Street	455 Shawnee Ln.
City/State	Waverly, OH	Greenfield, OH	Chillicothe, OH
NPA-nxx	740-941	937-981	740-779
Class of Facility	2	2	3
Primary Entry?	[Yes, Build]	[Yes, Build]	[Yes, Build]
Number of Fiber Strands	[Quantity]	[Quantity]	[Quantity]
Number of Copper Conductors	[Quantity]	[Quantity]	[Quantity]
Provisioning Cost-Primary	[Dollar Amount]	[Dollar Amount]	[Dollar Amount]
Diverse Entry?	[Yes, Build]	[Yes, Build]	[Yes, Build]
Number of Fiber Strands	[Quantity]	[Quantity]	[Quantity]
Number of Copper Conductors	[Quantity]	[Quantity]	[Quantity]
Diverse Route to POP?	[Yes, Build]	[Yes, Build]	[Yes, Build]
Diversity Method	[A, B, C, Other]	[A, B, C, Other]	[A, B, C, Other]
Provisioning Cost-Diverse	[Dollar Amount]	[Dollar Amount]	[Dollar Amount]
<b>Dedicated Services?</b>	[Yes, No]	[Yes, No]	[Yes, No]
Rate Table(s)	[Rate Table Number(s)]	[Rate Table Number(s)]	[Rate Table Number(s)]
Carrier(s) Providing	[Carrier ID(s)]	[Carrier ID(s)]	[Carrier ID(s)]
<b>Shared Services?</b>	[Yes, No]	[Yes, No]	[Yes, No]
Rate Table(s)	[Rate Table Number(s)]	[Rate Table Number(s)]	[Rate Table Number(s)]
Carrier(s) Providing	[Carrier ID(s)]	[Carrier ID(s)]	[Carrier ID(s)]

**SOHCN Facility Response Tables**

<b>SOHCN Entity</b>	Adena Health System	Adena Health System	Adena Health System
<b>SOHCN Facility</b>	Medical Office Building	Urgent Care	Rehab & Wellness Center
<b>SOHCN Facility ID</b>	1007	1008	1009
Address	4439 SR 159	55 Centennial Blvd.	445 Shawnee Ln.
City/State	Chillicothe, OH	Chillicothe, OH	Chillicothe, OH
NPA-nxx	740-779	740-779	740-779
Class of Facility	3	2	3
Primary Entry?	[Yes, Build]	[Yes, Build]	[Yes, Build]
Number of Fiber Strands	[Quantity]	[Quantity]	[Quantity]
Number of Copper Conductors	[Quantity]	[Quantity]	[Quantity]
Provisioning Cost-Primary	[Dollar Amount]	[Dollar Amount]	[Dollar Amount]
Diverse Entry?	[Yes, Build]	[Yes, Build]	[Yes, Build]
Number of Fiber Strands	[Quantity]	[Quantity]	[Quantity]
Number of Copper Conductors	[Quantity]	[Quantity]	[Quantity]
Diverse Route to POP?	[Yes, Build]	[Yes, Build]	[Yes, Build]
Diversity Method	[A, B, C, Other]	[A, B, C, Other]	[A, B, C, Other]
Provisioning Cost-Diverse	[Dollar Amount]	[Dollar Amount]	[Dollar Amount]
<b>Dedicated Services?</b>	[Yes, No]	[Yes, No]	[Yes, No]
Rate Table(s)	Rate Table Number(s)	Rate Table Number(s)	Rate Table Number(s)
Carrier(s) Providing	[Carrier ID(s)]	[Carrier ID(s)]	[Carrier ID(s)]
<b>Shared Services?</b>	[Yes, No]	[Yes, No]	[Yes, No]
Rate Table(s)	Rate Table Number(s)	Rate Table Number(s)	Rate Table Number(s)
Carrier(s) Providing	[Carrier ID(s)]	[Carrier ID(s)]	[Carrier ID(s)]

**SOHCN Facility Response Tables**

<b>SOHCN Entity</b>	Adena Health System	Adena Health System	Adena Health System
<b>SOHCN Facility</b>	Dr. Sean Choice	Dr. Dale Hume	Dr. Ed DelGrosso
<b>SOHCN Facility ID</b>	1010	1011	1012
Address	3 Belmont Ct.	33 Stagecoach Rd.	2050 Rocky Rd.
City/State	Chillicothe, OH	Chillicothe, OH	Chillicothe
NPA-nxx			
Class of Facility	4	4	4
Primary Entry?	[Yes, Build]	[Yes, Build]	[Yes, Build]
Number of Fiber Strands	[Quantity]	[Quantity]	[Quantity]
Number of Copper Conductors	[Quantity]	[Quantity]	[Quantity]
Provisioning Cost-Primary	[Dollar Amount]	[Dollar Amount]	[Dollar Amount]
Diverse Entry?	[Yes, Build]	[Yes, Build]	[Yes, Build]
Number of Fiber Strands	[Quantity]	[Quantity]	[Quantity]
Number of Copper Conductors	[Quantity]	[Quantity]	[Quantity]
Diverse Route to POP?	[Yes, Build]	[Yes, Build]	[Yes, Build]
Diversity Method	[A, B, C, Other]	[A, B, C, Other]	[A, B, C, Other]
Provisioning Cost-Diverse	[Dollar Amount]	[Dollar Amount]	[Dollar Amount]
<b>Dedicated Services?</b>	[Yes, No]	[Yes, No]	[Yes, No]
Rate Table(s)	Rate Table Number(s)	Rate Table Number(s)	Rate Table Number(s)
Carrier(s) Providing	[Carrier ID(s)]	[Carrier ID(s)]	[Carrier ID(s)]
<b>Shared Services?</b>	[Yes, No]	[Yes, No]	[Yes, No]
Rate Table(s)	Rate Table Number(s)	Rate Table Number(s)	Rate Table Number(s)
Carrier(s) Providing	[Carrier ID(s)]	[Carrier ID(s)]	[Carrier ID(s)]

**SOHCN Facility Response Tables**

<b>SOHCN Entity</b>	Adena Health System	Adena Health System	CAC of Pike County
<b>SOHCN Facility</b>	Dr. Gabe Pedicelli	Dr. Bryan Borland	Family Health Center
<b>SOHCN Facility ID</b>	1013	1014	1015
Address	3910 Tarrington Ln.	29651 Wolfe Rd.	227 Valleyview Dr.
City/State	Columbus, OH	Circleville, OH	Waverly, OH
NPA-nxx			740-947
Class of Facility	4	4	3
Primary Entry?	[Yes, Build]	[Yes, Build]	[Yes, Build]
Number of Fiber Strands	[Quantity]	[Quantity]	[Quantity]
Number of Copper Conductors	[Quantity]	[Quantity]	[Quantity]
Provisioning Cost-Primary	[Dollar Amount]	[Dollar Amount]	[Dollar Amount]
Diverse Entry?	[Yes, Build]	[Yes, Build]	[Yes, Build]
Number of Fiber Strands	[Quantity]	[Quantity]	[Quantity]
Number of Copper Conductors	[Quantity]	[Quantity]	[Quantity]
Diverse Route to POP?	[Yes, Build]	[Yes, Build]	[Yes, Build]
Diversity Method	[A, B, C, Other]	[A, B, C, Other]	[A, B, C, Other]
Provisioning Cost-Diverse	[Dollar Amount]	[Dollar Amount]	[Dollar Amount]
<b>Dedicated Services?</b>	[Yes, No]	[Yes, No]	[Yes, No]
Rate Table(s)	Rate Table Number(s)	Rate Table Number(s)	Rate Table Number(s)
Carrier(s) Providing	[Carrier ID(s)]	[Carrier ID(s)]	[Carrier ID(s)]
<b>Shared Services?</b>	[Yes, No]	[Yes, No]	[Yes, No]
Rate Table(s)	Rate Table Number(s)	Rate Table Number(s)	Rate Table Number(s)
Carrier(s) Providing	[Carrier ID(s)]	[Carrier ID(s)]	[Carrier ID(s)]

**SOHCN Facility Response Tables**

<b>SOHCN Entity</b>	CAC of Pike County	CAC of Pike County	CAC of Pike County
<b>SOHCN Facility</b>	Family Health Center	Family Health Center	Family Health Center
<b>SOHCN Facility ID</b>	1016	1017	1018
Address	7777 US Rt 23	23030 SR 73	14590 SR 93
City/State	Piketon, OH	Portsmouth, OH	Jackson, OH
NPA-nxx	740-289	740-858	740-286
Class of Facility	3	3	3
Primary Entry?	[Yes, Build]	[Yes, Build]	[Yes, Build]
Number of Fiber Strands	[Quantity]	[Quantity]	[Quantity]
Number of Copper Conductors	[Quantity]	[Quantity]	[Quantity]
Provisioning Cost-Primary	[Dollar Amount]	[Dollar Amount]	[Dollar Amount]
Diverse Entry?	[Yes, Build]	[Yes, Build]	[Yes, Build]
Number of Fiber Strands	[Quantity]	[Quantity]	[Quantity]
Number of Copper Conductors	[Quantity]	[Quantity]	[Quantity]
Diverse Route to POP?	[Yes, Build]	[Yes, Build]	[Yes, Build]
Diversity Method	[A, B, C, Other]	[A, B, C, Other]	[A, B, C, Other]
Provisioning Cost-Diverse	[Dollar Amount]	[Dollar Amount]	[Dollar Amount]
<b>Dedicated Services?</b>	[Yes, No]	[Yes, No]	[Yes, No]
Rate Table(s)	Rate Table Number(s)	Rate Table Number(s)	Rate Table Number(s)
Carrier(s) Providing	[Carrier ID(s)]	[Carrier ID(s)]	[Carrier ID(s)]
<b>Shared Services?</b>	[Yes, No]	[Yes, No]	[Yes, No]
Rate Table(s)	Rate Table Number(s)	Rate Table Number(s)	Rate Table Number(s)
Carrier(s) Providing	[Carrier ID(s)]	[Carrier ID(s)]	[Carrier ID(s)]

**SOHCN Facility Response Tables**

<b>SOHCN Entity</b>	Family Healthcare, Inc.	Family Healthcare, Inc.	Family Healthcare, Inc.
<b>SOHCN Facility</b>	Family Health Clinic	Family Health Clinic	Family Health Clinic
<b>SOHCN Facility ID</b>	1019	1020	1021
Address	1049 Western Ave.	88 N Plains Rd Ste. 1	113 E. Memorial Dr.
City/State	Chillicothe, OH	The Plains, OH	Pomeroy, OH
NPA-nxx	740-773	740-797	740-992
Class of Facility	3	3	3
Primary Entry?	[Yes, Build]	[Yes, Build]	[Yes, Build]
Number of Fiber Strands	[Quantity]	[Quantity]	[Quantity]
Number of Copper Conductors	[Quantity]	[Quantity]	[Quantity]
Provisioning Cost-Primary	[Dollar Amount]	[Dollar Amount]	[Dollar Amount]
Diverse Entry?	[Yes, Build]	[Yes, Build]	[Yes, Build]
Number of Fiber Strands	[Quantity]	[Quantity]	[Quantity]
Number of Copper Conductors	[Quantity]	[Quantity]	[Quantity]
Diverse Route to POP?	[Yes, Build]	[Yes, Build]	[Yes, Build]
Diversity Method	[A, B, C, Other]	[A, B, C, Other]	[A, B, C, Other]
Provisioning Cost-Diverse	[Dollar Amount]	[Dollar Amount]	[Dollar Amount]
<b>Dedicated Services?</b>	[Yes, No]	[Yes, No]	[Yes, No]
Rate Table(s)	Rate Table Number(s)	Rate Table Number(s)	Rate Table Number(s)
Carrier(s) Providing	[Carrier ID(s)]	[Carrier ID(s)]	[Carrier ID(s)]
<b>Shared Services?</b>	[Yes, No]	[Yes, No]	[Yes, No]
Rate Table(s)	Rate Table Number(s)	Rate Table Number(s)	Rate Table Number(s)
Carrier(s) Providing	[Carrier ID(s)]	[Carrier ID(s)]	[Carrier ID(s)]

**SOHCN Facility Response Tables**

<b>SOHCN Entity</b>	Family Healthcare, Inc.	Shawnee Mental Health Center, Inc.	Shawnee Mental Health Center, Inc.
<b>SOHCN Facility</b>	Family Health Clinic	Mental Health Center	Mental Health Center
<b>SOHCN Facility ID</b>	1022	1023	1024
Address	31891 SR 93 North	901 Washington St.	192 Chestnut Ridge
City/State	McArthur, OH	Portsmouth, OH	West Union, OH
NPA-nxx	740-596	740-355	937-544
Class of Facility	3	3	3
Primary Entry?	[Yes, Build]	[Yes, Build]	[Yes, Build]
Number of Fiber Strands	[Quantity]	[Quantity]	[Quantity]
Number of Copper Conductors	[Quantity]	[Quantity]	[Quantity]
Provisioning Cost-Primary	[Dollar Amount]	[Dollar Amount]	[Dollar Amount]
Diverse Entry?	[Yes, Build]	[Yes, Build]	[Yes, Build]
Number of Fiber Strands	[Quantity]	[Quantity]	[Quantity]
Number of Copper Conductors	[Quantity]	[Quantity]	[Quantity]
Diverse Route to POP?	[Yes, Build]	[Yes, Build]	[Yes, Build]
Diversity Method	[A, B, C, Other]	[A, B, C, Other]	[A, B, C, Other]
Provisioning Cost-Diverse	[Dollar Amount]	[Dollar Amount]	[Dollar Amount]
<b>Dedicated Services?</b>	[Yes, No]	[Yes, No]	[Yes, No]
Rate Table(s)	[Rate Table Number(s)]	[Rate Table Number(s)]	[Rate Table Number(s)]
Carrier(s) Providing	[Carrier ID(s)]	[Carrier ID(s)]	[Carrier ID(s)]
<b>Shared Services?</b>	[Yes, No]	[Yes, No]	[Yes, No]
Rate Table(s)	[Rate Table Number(s)]	[Rate Table Number(s)]	[Rate Table Number(s)]
Carrier(s) Providing	[Carrier ID(s)]	[Carrier ID(s)]	[Carrier ID(s)]

**SOHCN Facility Response Tables**

<b>SOHCN Entity</b>	Shawnee Mental Health Center, Inc.	Shawnee Mental Health Center, Inc.	Shawnee Mental Health Center, Inc.
<b>SOHCN Facility</b>	Mental Health Center	Mental Health Center	Mental Health Crisis Center
<b>SOHCN Facility ID</b>	1025	1026	1027
Address	715 Lane St.	225 Carlton Davidson	2310 Vinton Ave.
City/State	Coal Grove, OH	Coal Grove, OH	Portsmouth, OH
NPA-nxx	740-533	740-355	740-354
Class of Facility	3	3	3
Primary Entry?	[Yes, Build]	[Yes, Build]	[Yes, Build]
Number of Fiber Strands	[Quantity]	[Quantity]	[Quantity]
Number of Copper Conductors	[Quantity]	[Quantity]	[Quantity]
Provisioning Cost-Primary	[Dollar Amount]	[Dollar Amount]	[Dollar Amount]
Diverse Entry?	[Yes, Build]	[Yes, Build]	[Yes, Build]
Number of Fiber Strands	[Quantity]	[Quantity]	[Quantity]
Number of Copper Conductors	[Quantity]	[Quantity]	[Quantity]
Diverse Route to POP?	[Yes, Build]	[Yes, Build]	[Yes, Build]
Diversity Method	[A, B, C, Other]	[A, B, C, Other]	[A, B, C, Other]
Provisioning Cost-Diverse	[Dollar Amount]	[Dollar Amount]	[Dollar Amount]
<b>Dedicated Services?</b>	[Yes, No]	[Yes, No]	[Yes, No]
Rate Table(s)	[Rate Table Number(s)]	[Rate Table Number(s)]	[Rate Table Number(s)]
Carrier(s) Providing	[Carrier ID(s)]	[Carrier ID(s)]	[Carrier ID(s)]
<b>Shared Services?</b>	[Yes, No]	[Yes, No]	[Yes, No]
Rate Table(s)	[Rate Table Number(s)]	[Rate Table Number(s)]	[Rate Table Number(s)]
Carrier(s) Providing	[Carrier ID(s)]	[Carrier ID(s)]	[Carrier ID(s)]

**SOHCN Facility Response Tables**

<b>SOHCN Entity</b>	Scioto Paint Valley Mental Health Center	Scioto Paint Valley Mental Health Center	Scioto Paint Valley Mental Health Center
<b>SOHCN Facility</b>	Main Office	Fayette County Clinic	Floyd Simantel Clinic
<b>SOHCN Facility ID</b>	1028	1029	1030
Address	4449 SR 159	1300 E. Paint St.	312 E. Second St.
City/State	Chillicothe, OH	OH	Chillicothe, OH
NPA-nxx	740-775	740-335	740-775
Class of Facility	3	3	3
Primary Entry?	[Yes, Build]	[Yes, Build]	[Yes, Build]
Number of Fiber Strands	[Quantity]	[Quantity]	[Quantity]
Number of Copper Conductors	[Quantity]	[Quantity]	[Quantity]
Provisioning Cost-Primary	[Dollar Amount]	[Dollar Amount]	[Dollar Amount]
Diverse Entry?	[Yes, Build]	[Yes, Build]	[Yes, Build]
Number of Fiber Strands	[Quantity]	[Quantity]	[Quantity]
Number of Copper Conductors	[Quantity]	[Quantity]	[Quantity]
Diverse Route to POP?	[Yes, Build]	[Yes, Build]	[Yes, Build]
Diversity Method	[A, B, C, Other]	[A, B, C, Other]	[A, B, C, Other]
Provisioning Cost-Diverse	[Dollar Amount]	[Dollar Amount]	[Dollar Amount]
<b>Dedicated Services?</b>	[Yes, No]	[Yes, No]	[Yes, No]
Rate Table(s)	[Rate Table Number(s)]	[Rate Table Number(s)]	[Rate Table Number(s)]
Carrier(s) Providing	[Carrier ID(s)]	[Carrier ID(s)]	[Carrier ID(s)]
<b>Shared Services?</b>	[Yes, No]	[Yes, No]	[Yes, No]
Rate Table(s)	[Rate Table Number(s)]	[Rate Table Number(s)]	[Rate Table Number(s)]
Carrier(s) Providing	[Carrier ID(s)]	[Carrier ID(s)]	[Carrier ID(s)]

**SOHCN Facility Response Tables**

<b>SOHCN Entity</b>	Scioto Paint Valley Mental Health Center	Scioto Paint Valley Mental Health Center	Scioto Paint Valley Mental Health Center
<b>SOHCN Facility</b>	Great Seal Clinic	Lynn Goff Clinic	Highland County Clinic
<b>SOHCN Facility ID</b>	1031	1032	1033
Address	126 E. Second St.	134 Jefferson St.	108 Erin Court
City/State	Chillicothe, OH	Greenfield, OH	Hillsboro, OH
NPA-nxx	740-773	937-981	937-393
Class of Facility	3	3	3
Primary Entry?	[Yes, Build]	[Yes, Build]	[Yes, Build]
Number of Fiber Strands	[Quantity]	[Quantity]	[Quantity]
Number of Copper Conductors	[Quantity]	[Quantity]	[Quantity]
Provisioning Cost-Primary	[Dollar Amount]	[Dollar Amount]	[Dollar Amount]
Diverse Entry?	[Yes, Build]	[Yes, Build]	[Yes, Build]
Number of Fiber Strands	[Quantity]	[Quantity]	[Quantity]
Number of Copper Conductors	[Quantity]	[Quantity]	[Quantity]
Diverse Route to POP?	[Yes, Build]	[Yes, Build]	[Yes, Build]
Diversity Method	[A, B, C, Other]	[A, B, C, Other]	[A, B, C, Other]
Provisioning Cost-Diverse	[Dollar Amount]	[Dollar Amount]	[Dollar Amount]
<b>Dedicated Services?</b>	[Yes, No]	[Yes, No]	[Yes, No]
Rate Table(s)	[Rate Table Number(s)]	[Rate Table Number(s)]	[Rate Table Number(s)]
Carrier(s) Providing	[Carrier ID(s)]	[Carrier ID(s)]	[Carrier ID(s)]
<b>Shared Services?</b>	[Yes, No]	[Yes, No]	[Yes, No]
Rate Table(s)	[Rate Table Number(s)]	[Rate Table Number(s)]	[Rate Table Number(s)]
Carrier(s) Providing	[Carrier ID(s)]	[Carrier ID(s)]	[Carrier ID(s)]

**SOHCN Facility Response Tables**

<b>SOHCN Entity</b>	Scioto Paint Valley Mental Health Center	Scioto Paint Valley Mental Health Center	Woodland Centers, Inc.
<b>SOHCN Facility</b>	Pickaway County Clinic	Pike County Clinic	Gallia Office
<b>SOHCN Facility ID</b>	1034	1035	1036
Address	145 Morris Rd.	102 Dawn Ln.	3086 SR 160
City/State	Circleville, OH	Waverly, OH	Gallipolis, OH
NPA-nxx	740-474	740-947	740-446
Class of Facility	3	3	3
Primary Entry?	[Yes, Build]	[Yes, Build]	[Yes, Build]
Number of Fiber Strands	[Quantity]	[Quantity]	[Quantity]
Number of Copper Conductors	[Quantity]	[Quantity]	[Quantity]
Provisioning Cost-Primary	[Dollar Amount]	[Dollar Amount]	[Dollar Amount]
Diverse Entry?	[Yes, Build]	[Yes, Build]	[Yes, Build]
Number of Fiber Strands	[Quantity]	[Quantity]	[Quantity]
Number of Copper Conductors	[Quantity]	[Quantity]	[Quantity]
Diverse Route to POP?	[Yes, Build]	[Yes, Build]	[Yes, Build]
Diversity Method	[A, B, C, Other]	[A, B, C, Other]	[A, B, C, Other]
Provisioning Cost-Diverse	[Dollar Amount]	[Dollar Amount]	[Dollar Amount]
<b>Dedicated Services?</b>	[Yes, No]	[Yes, No]	[Yes, No]
Rate Table(s)	[Rate Table Number(s)]	[Rate Table Number(s)]	[Rate Table Number(s)]
Carrier(s) Providing	[Carrier ID(s)]	[Carrier ID(s)]	[Carrier ID(s)]
<b>Shared Services?</b>	[Yes, No]	[Yes, No]	[Yes, No]
Rate Table(s)	[Rate Table Number(s)]	[Rate Table Number(s)]	[Rate Table Number(s)]
Carrier(s) Providing	[Carrier ID(s)]	[Carrier ID(s)]	[Carrier ID(s)]

**SOHCN Facility Response Tables**

<b>SOHCN Entity</b>	Woodland Centers, Inc.	Woodland Centers, Inc.	The Counseling Center, Inc.
<b>SOHCN Facility</b>	Outpatient Clinic	Outpatient Clinic	Counseling Center & Family Health Clinic
<b>SOHCN Facility ID</b>	1037	1038	1039
Address	1 Acy Ave. Suite B	112 E. Memorial Dr.	1634 11th St.
City/State	Jackson, OH	Pomeroy, OH	Portsmouth, OH
NPA-nxx	740-286	740-992	740-354
Class of Facility	3	3	3
Primary Entry?	[Yes, Build]	[Yes, Build]	[Yes, Build]
Number of Fiber Strands	[Quantity]	[Quantity]	[Quantity]
Number of Copper Conductors	[Quantity]	[Quantity]	[Quantity]
Provisioning Cost-Primary	[Dollar Amount]	[Dollar Amount]	[Dollar Amount]
Diverse Entry?	[Yes, Build]	[Yes, Build]	[Yes, Build]
Number of Fiber Strands	[Quantity]	[Quantity]	[Quantity]
Number of Copper Conductors	[Quantity]	[Quantity]	[Quantity]
Diverse Route to POP?	[Yes, Build]	[Yes, Build]	[Yes, Build]
Diversity Method	[A, B, C, Other]	[A, B, C, Other]	[A, B, C, Other]
Provisioning Cost-Diverse	[Dollar Amount]	[Dollar Amount]	[Dollar Amount]
<b>Dedicated Services?</b>	[Yes, No]	[Yes, No]	[Yes, No]
Rate Table(s)	[Rate Table Number(s)]	[Rate Table Number(s)]	[Rate Table Number(s)]
Carrier(s) Providing	[Carrier ID(s)]	[Carrier ID(s)]	[Carrier ID(s)]
<b>Shared Services?</b>	[Yes, No]	[Yes, No]	[Yes, No]
Rate Table(s)	[Rate Table Number(s)]	[Rate Table Number(s)]	[Rate Table Number(s)]
Carrier(s) Providing	[Carrier ID(s)]	[Carrier ID(s)]	[Carrier ID(s)]

**SOHCN Facility Response Tables**

<b>SOHCN Entity</b>	The Counseling Center, Inc.	The Counseling Center, Inc.	The Counseling Center, Inc.
<b>SOHCN Facility</b>	Adams County Office	Stepping Stone House for Women	Stepping Stone House for Women
<b>SOHCN Facility ID</b>	1040	1041	1042
Address	829 E. Walnut St.	1409 Second St.	605 Front St.
City/State	West Union, OH	Portsmouth, OH	Portsmouth, OH
NPA-nxx	937-544	740-354	740-353
Class of Facility	3	3	3
Primary Entry?	[Yes, Build]	[Yes, Build]	[Yes, Build]
Number of Fiber Strands	[Quantity]	[Quantity]	[Quantity]
Number of Copper Conductors	[Quantity]	[Quantity]	[Quantity]
Provisioning Cost-Primary	[Dollar Amount]	[Dollar Amount]	[Dollar Amount]
Diverse Entry?	[Yes, Build]	[Yes, Build]	[Yes, Build]
Number of Fiber Strands	[Quantity]	[Quantity]	[Quantity]
Number of Copper Conductors	[Quantity]	[Quantity]	[Quantity]
Diverse Route to POP?	[Yes, Build]	[Yes, Build]	[Yes, Build]
Diversity Method	[A, B, C, Other]	[A, B, C, Other]	[A, B, C, Other]
Provisioning Cost-Diverse	[Dollar Amount]	[Dollar Amount]	[Dollar Amount]
<b>Dedicated Services?</b>	[Yes, No]	[Yes, No]	[Yes, No]
Rate Table(s)	Rate Table Number(s)	Rate Table Number(s)	Rate Table Number(s)
Carrier(s) Providing	[Carrier ID(s)]	[Carrier ID(s)]	[Carrier ID(s)]
<b>Shared Services?</b>	[Yes, No]	[Yes, No]	[Yes, No]
Rate Table(s)	Rate Table Number(s)	Rate Table Number(s)	Rate Table Number(s)
Carrier(s) Providing	[Carrier ID(s)]	[Carrier ID(s)]	[Carrier ID(s)]

**SOHCN Facility Response Tables**

<b>SOHCN Entity</b>	The Counseling Center, Inc.	The Counseling Center, Inc.	The Counseling Center, Inc.
<b>SOHCN Facility</b>	Bridges for Adolescent Girls	Marsh House for Men I	Marsh House for Men II
<b>SOHCN Facility ID</b>	1043	1044	1045
Address	1311 Second St.	1216 Fourth St.	956 Rapp Montgomery Rd
City/State	Portsmouth, OH	Portsmouth, OH	Lucasville, OH
NPA-nxx	740-353	740-353	740-820
Class of Facility	3	3	3
Primary Entry?	[Yes, Build]	[Yes, Build]	[Yes, Build]
Number of Fiber Strands	[Quantity]	[Quantity]	[Quantity]
Number of Copper Conductors	[Quantity]	[Quantity]	[Quantity]
Provisioning Cost-Primary	[Dollar Amount]	[Dollar Amount]	[Dollar Amount]
Diverse Entry?	[Yes, Build]	[Yes, Build]	[Yes, Build]
Number of Fiber Strands	[Quantity]	[Quantity]	[Quantity]
Number of Copper Conductors	[Quantity]	[Quantity]	[Quantity]
Diverse Route to POP?	[Yes, Build]	[Yes, Build]	[Yes, Build]
Diversity Method	[A, B, C, Other]	[A, B, C, Other]	[A, B, C, Other]
Provisioning Cost-Diverse	[Dollar Amount]	[Dollar Amount]	[Dollar Amount]
<b>Dedicated Services?</b>	[Yes, No]	[Yes, No]	[Yes, No]
Rate Table(s)	[Rate Table Number(s)]	[Rate Table Number(s)]	[Rate Table Number(s)]
Carrier(s) Providing	[Carrier ID(s)]	[Carrier ID(s)]	[Carrier ID(s)]
<b>Shared Services?</b>	[Yes, No]	[Yes, No]	[Yes, No]
Rate Table(s)	[Rate Table Number(s)]	[Rate Table Number(s)]	[Rate Table Number(s)]
Carrier(s) Providing	[Carrier ID(s)]	[Carrier ID(s)]	[Carrier ID(s)]

**SOHCN Facility Response Tables**

<b>SOHCN Entity</b>	The Counseling Center, Inc.	The Counseling Center, Inc.	CAO Scioto County
<b>SOHCN Facility</b>	Ray's Place	Hopeworks	Health Program
<b>SOHCN Facility ID</b>	1046	1047	1048
Address	1023 Fourth St.	816 Fourth St.	411 Second St.
City/State	Portsmouth, OH	Portsmouth, OH	Portsmouth, OH
NPA-nxx	740-354	740-353	740-353
Class of Facility	3	3	3
Primary Entry?	[Yes, Build]	[Yes, Build]	[Yes, Build]
Number of Fiber Strands	[Quantity]	[Quantity]	[Quantity]
Number of Copper Conductors	[Quantity]	[Quantity]	[Quantity]
Provisioning Cost-Primary	[Dollar Amount]	[Dollar Amount]	[Dollar Amount]
Diverse Entry?	[Yes, Build]	[Yes, Build]	[Yes, Build]
Number of Fiber Strands	[Quantity]	[Quantity]	[Quantity]
Number of Copper Conductors	[Quantity]	[Quantity]	[Quantity]
Diverse Route to POP?	[Yes, Build]	[Yes, Build]	[Yes, Build]
Diversity Method	[A, B, C, Other]	[A, B, C, Other]	[A, B, C, Other]
Provisioning Cost-Diverse	[Dollar Amount]	[Dollar Amount]	[Dollar Amount]
<b>Dedicated Services?</b>	[Yes, No]	[Yes, No]	[Yes, No]
Rate Table(s)	[Rate Table Number(s)]	[Rate Table Number(s)]	[Rate Table Number(s)]
Carrier(s) Providing	[Carrier ID(s)]	[Carrier ID(s)]	[Carrier ID(s)]
<b>Shared Services?</b>	[Yes, No]	[Yes, No]	[Yes, No]
Rate Table(s)	[Rate Table Number(s)]	[Rate Table Number(s)]	[Rate Table Number(s)]
Carrier(s) Providing	[Carrier ID(s)]	[Carrier ID(s)]	[Carrier ID(s)]

**SOHCN Facility Response Tables**

<b>SOHCN Entity</b>	Berger Health System	Holzer Consolidated Health Systems	Holzer Consolidated Health Systems
<b>SOHCN Facility</b>	Berger Health System	Medical Center	The Medical Plaza
<b>SOHCN Facility ID</b>	1049	1050	1051
Address	600 N. Pickaway St.	100 Jackson Pike	936 SR 160
City/State	Circleville, OH	Gallipolis, OH	Gallipolis, OH
NPA-nxx	740-474	740-446	740-446
Class of Facility	1	1	3
Primary Entry?	[Yes, Build]	[Yes, Build]	[Yes, Build]
Number of Fiber Strands	[Quantity]	[Quantity]	[Quantity]
Number of Copper Conductors	[Quantity]	[Quantity]	[Quantity]
Provisioning Cost-Primary	[Dollar Amount]	[Dollar Amount]	[Dollar Amount]
Diverse Entry?	[Yes, Build]	[Yes, Build]	[Yes, Build]
Number of Fiber Strands	[Quantity]	[Quantity]	[Quantity]
Number of Copper Conductors	[Quantity]	[Quantity]	[Quantity]
Diverse Route to POP?	[Yes, Build]	[Yes, Build]	[Yes, Build]
Diversity Method	[A, B, C, Other]	[A, B, C, Other]	[A, B, C, Other]
Provisioning Cost-Diverse	[Dollar Amount]	[Dollar Amount]	[Dollar Amount]
<b>Dedicated Services?</b>	[Yes, No]	[Yes, No]	[Yes, No]
Rate Table(s)	[Rate Table Number(s)]	[Rate Table Number(s)]	[Rate Table Number(s)]
Carrier(s) Providing	[Carrier ID(s)]	[Carrier ID(s)]	[Carrier ID(s)]
<b>Shared Services?</b>	[Yes, No]	[Yes, No]	[Yes, No]
Rate Table(s)	[Rate Table Number(s)]	[Rate Table Number(s)]	[Rate Table Number(s)]
Carrier(s) Providing	[Carrier ID(s)]	[Carrier ID(s)]	[Carrier ID(s)]

**SOHCN Facility Response Tables**

<b>SOHCN Entity</b>	Holzer Consolidated Health Systems	Holzer Consolidated Health Systems	Holzer Consolidated Health Systems
<b>SOHCN Facility</b>	Dental Health Partners	Jenkins Memorial Health	Medical Center
<b>SOHCN Facility ID</b>	1052	1053	1054
Address	190 Water St.	140 Jenkins Memorial Rd	500 Burlington Rd.
City/State	Jackson, OH	Wellston, OH	Jackson, OH
NPA-nxx	740-286	740-384	740-288
Class of Facility	3	3	1
Primary Entry?	[Yes, Build]	[Yes, Build]	[Yes, Build]
Number of Fiber Strands	[Quantity]	[Quantity]	[Quantity]
Number of Copper Conductors	[Quantity]	[Quantity]	[Quantity]
Provisioning Cost-Primary	[Dollar Amount]	[Dollar Amount]	[Dollar Amount]
Diverse Entry?	[Yes, Build]	[Yes, Build]	[Yes, Build]
Number of Fiber Strands	[Quantity]	[Quantity]	[Quantity]
Number of Copper Conductors	[Quantity]	[Quantity]	[Quantity]
Diverse Route to POP?	[Yes, Build]	[Yes, Build]	[Yes, Build]
Diversity Method	[A, B, C, Other]	[A, B, C, Other]	[A, B, C, Other]
Provisioning Cost-Diverse	[Dollar Amount]	[Dollar Amount]	[Dollar Amount]
<b>Dedicated Services?</b>	[Yes, No]	[Yes, No]	[Yes, No]
Rate Table(s)	Rate Table Number(s)	Rate Table Number(s)	Rate Table Number(s)
Carrier(s) Providing	[Carrier ID(s)]	[Carrier ID(s)]	[Carrier ID(s)]
<b>Shared Services?</b>	[Yes, No]	[Yes, No]	[Yes, No]
Rate Table(s)	Rate Table Number(s)	Rate Table Number(s)	Rate Table Number(s)
Carrier(s) Providing	[Carrier ID(s)]	[Carrier ID(s)]	[Carrier ID(s)]

**SOHCN Facility Response Tables**

<b>SOHCN Entity</b>	Holzer Consolidated Health Systems	Holzer Consolidated Health Systems	Family Addiction Community
<b>SOHCN Facility</b>	Assisted Living	Assisted Living	FACTS
<b>SOHCN Facility ID</b>	1055	1056	1057
Address	300 Brierwood Dr.	101 Markham Dr.	45 Olive St.
City/State	Gallipolis, OH	Jackson, OH	Gallipolis, OH
NPA-nxx	740-441	740-286	740-446
Class of Facility	3	3	3
Primary Entry?	[Yes, Build]	[Yes, Build]	[Yes, Build]
Number of Fiber Strands	[Quantity]	[Quantity]	[Quantity]
Number of Copper Conductors	[Quantity]	[Quantity]	[Quantity]
Provisioning Cost-Primary	[Dollar Amount]	[Dollar Amount]	[Dollar Amount]
Diverse Entry?	[Yes, Build]	[Yes, Build]	[Yes, Build]
Number of Fiber Strands	[Quantity]	[Quantity]	[Quantity]
Number of Copper Conductors	[Quantity]	[Quantity]	[Quantity]
Diverse Route to POP?	[Yes, Build]	[Yes, Build]	[Yes, Build]
Diversity Method	[A, B, C, Other]	[A, B, C, Other]	[A, B, C, Other]
Provisioning Cost-Diverse	[Dollar Amount]	[Dollar Amount]	[Dollar Amount]
<b>Dedicated Services?</b>	[Yes, No]	[Yes, No]	[Yes, No]
Rate Table(s)	[Rate Table Number(s)]	[Rate Table Number(s)]	[Rate Table Number(s)]
Carrier(s) Providing	[Carrier ID(s)]	[Carrier ID(s)]	[Carrier ID(s)]
<b>Shared Services?</b>	[Yes, No]	[Yes, No]	[Yes, No]
Rate Table(s)	[Rate Table Number(s)]	[Rate Table Number(s)]	[Rate Table Number(s)]
Carrier(s) Providing	[Carrier ID(s)]	[Carrier ID(s)]	[Carrier ID(s)]

**SOHCN Facility Response Tables**

<b>SOHCN Entity</b>	Family Addiction Community	CAO Ironton-Lawrence County	CAO Ironton-Lawrence County
<b>SOHCN Facility</b>	New Alternatives	I-L CAO	Family Guidance Center
<b>SOHCN Facility ID</b>	1058	1059	1060
Address	1 Acy Ave., Ste. A	305 N. 5th St.	518 S. 3rd St.
City/State	Jackson, OH	Ironton, OH	Ironton, OH
NPA-nxx	740-286	740-532	740-532
Class of Facility	3	3	3
Primary Entry?	[Yes, Build]	[Yes, Build]	[Yes, Build]
Number of Fiber Strands	[Quantity]	[Quantity]	[Quantity]
Number of Copper Conductors	[Quantity]	[Quantity]	[Quantity]
Provisioning Cost-Primary	[Dollar Amount]	[Dollar Amount]	[Dollar Amount]
Diverse Entry?	[Yes, Build]	[Yes, Build]	[Yes, Build]
Number of Fiber Strands	[Quantity]	[Quantity]	[Quantity]
Number of Copper Conductors	[Quantity]	[Quantity]	[Quantity]
Diverse Route to POP?	[Yes, Build]	[Yes, Build]	[Yes, Build]
Diversity Method	[A, B, C, Other]	[A, B, C, Other]	[A, B, C, Other]
Provisioning Cost-Diverse	[Dollar Amount]	[Dollar Amount]	[Dollar Amount]
<b>Dedicated Services?</b>	[Yes, No]	[Yes, No]	[Yes, No]
Rate Table(s)	[Rate Table Number(s)]	[Rate Table Number(s)]	[Rate Table Number(s)]
Carrier(s) Providing	[Carrier ID(s)]	[Carrier ID(s)]	[Carrier ID(s)]
<b>Shared Services?</b>	[Yes, No]	[Yes, No]	[Yes, No]
Rate Table(s)	[Rate Table Number(s)]	[Rate Table Number(s)]	[Rate Table Number(s)]
Carrier(s) Providing	[Carrier ID(s)]	[Carrier ID(s)]	[Carrier ID(s)]

**SOHCN Facility Response Tables**

<b>SOHCN Entity</b>	CAO Ironton-Lawrence County	CAO Ironton-Lawrence County	CAO Ironton-Lawrence County
<b>SOHCN Facility</b>	Chesapeake Family Medical Center	Kemp Family Medical Center	Ironton Family Medical Center
<b>SOHCN Facility ID</b>	1061	1062	1063
Address	717 3rd Ave.	223 Carlton Davidson Ln	304 N. 2nd St.
City/State	Chesapeake, OH	Coal Grove, OH	Ironton, OH
NPA-nxx	740-867	740-532	740-532
Class of Facility	3	3	3
Primary Entry?	[Yes, Build]	[Yes, Build]	[Yes, Build]
Number of Fiber Strands	[Quantity]	[Quantity]	[Quantity]
Number of Copper Conductors	[Quantity]	[Quantity]	[Quantity]
Provisioning Cost-Primary	[Dollar Amount]	[Dollar Amount]	[Dollar Amount]
Diverse Entry?	[Yes, Build]	[Yes, Build]	[Yes, Build]
Number of Fiber Strands	[Quantity]	[Quantity]	[Quantity]
Number of Copper Conductors	[Quantity]	[Quantity]	[Quantity]
Diverse Route to POP?	[Yes, Build]	[Yes, Build]	[Yes, Build]
Diversity Method	[A, B, C, Other]	[A, B, C, Other]	[A, B, C, Other]
Provisioning Cost-Diverse	[Dollar Amount]	[Dollar Amount]	[Dollar Amount]
<b>Dedicated Services?</b>	[Yes, No]	[Yes, No]	[Yes, No]
Rate Table(s)	[Rate Table Number(s)]	[Rate Table Number(s)]	[Rate Table Number(s)]
Carrier(s) Providing	[Carrier ID(s)]	[Carrier ID(s)]	[Carrier ID(s)]
<b>Shared Services?</b>	[Yes, No]	[Yes, No]	[Yes, No]
Rate Table(s)	[Rate Table Number(s)]	[Rate Table Number(s)]	[Rate Table Number(s)]
Carrier(s) Providing	[Carrier ID(s)]	[Carrier ID(s)]	[Carrier ID(s)]

**SOHCN Facility Response Tables**

<b>SOHCN Entity</b>	CAO Ironton-Lawrence County	Adams County Regional Medical	Doctors Hospital of Nelsonville
<b>SOHCN Facility</b>	South Point Family Medical Center	Regional Medical Center	Doctors Hospital
<b>SOHCN Facility ID</b>	1064	1065	1066
Address	55 Twp. Rd. 508E	230 Medical Center Dr.	1950 Mount St. Mary Dr
City/State	South Point, OH	Seaman, OH	Nelsonville, OH
NPA-nxx	740-377	937-386	740-753
Class of Facility	3	1	2
Primary Entry?	[Yes, Build]	[Yes, Build]	[Yes, Build]
Number of Fiber Strands	[Quantity]	[Quantity]	[Quantity]
Number of Copper Conductors	[Quantity]	[Quantity]	[Quantity]
Provisioning Cost-Primary	[Dollar Amount]	[Dollar Amount]	[Dollar Amount]
Diverse Entry?	[Yes, Build]	[Yes, Build]	[Yes, Build]
Number of Fiber Strands	[Quantity]	[Quantity]	[Quantity]
Number of Copper Conductors	[Quantity]	[Quantity]	[Quantity]
Diverse Route to POP?	[Yes, Build]	[Yes, Build]	[Yes, Build]
Diversity Method	[A, B, C, Other]	[A, B, C, Other]	[A, B, C, Other]
Provisioning Cost-Diverse	[Dollar Amount]	[Dollar Amount]	[Dollar Amount]
<b>Dedicated Services?</b>	[Yes, No]	[Yes, No]	[Yes, No]
Rate Table(s)	[Rate Table Number(s)]	[Rate Table Number(s)]	[Rate Table Number(s)]
Carrier(s) Providing	[Carrier ID(s)]	[Carrier ID(s)]	[Carrier ID(s)]
<b>Shared Services?</b>	[Yes, No]	[Yes, No]	[Yes, No]
Rate Table(s)	[Rate Table Number(s)]	[Rate Table Number(s)]	[Rate Table Number(s)]
Carrier(s) Providing	[Carrier ID(s)]	[Carrier ID(s)]	[Carrier ID(s)]

**SOHCN Facility Response Tables**

<b>SOHCN Entity</b>	Pike Community Hospital	Pike Community Hospital	Highland District Hospital
<b>SOHCN Facility</b>	Pike Community Hospital	Piketon Professional Center	Highland District Hospital
<b>SOHCN Facility ID</b>	1067	1068	1069
Address	100 Dawn Ln.	100 Indian Ridge Dr, Ste. 1	1275 N. High St.
City/State	Waverly, OH	Piketon, OH	Hillsboro, OH
NPA-nxx	740-947	740-289	937-393
Class of Facility	2	3	2
Primary Entry?	[Yes, Build]	[Yes, Build]	[Yes, Build]
Number of Fiber Strands	[Quantity]	[Quantity]	[Quantity]
Number of Copper Conductors	[Quantity]	[Quantity]	[Quantity]
Provisioning Cost-Primary	[Dollar Amount]	[Dollar Amount]	[Dollar Amount]
Diverse Entry?	[Yes, Build]	[Yes, Build]	[Yes, Build]
Number of Fiber Strands	[Quantity]	[Quantity]	[Quantity]
Number of Copper Conductors	[Quantity]	[Quantity]	[Quantity]
Diverse Route to POP?	[Yes, Build]	[Yes, Build]	[Yes, Build]
Diversity Method	[A, B, C, Other]	[A, B, C, Other]	[A, B, C, Other]
Provisioning Cost-Diverse	[Dollar Amount]	[Dollar Amount]	[Dollar Amount]
<b>Dedicated Services?</b>	[Yes, No]	[Yes, No]	[Yes, No]
Rate Table(s)	[Rate Table Number(s)]	[Rate Table Number(s)]	[Rate Table Number(s)]
Carrier(s) Providing	[Carrier ID(s)]	[Carrier ID(s)]	[Carrier ID(s)]
<b>Shared Services?</b>	[Yes, No]	[Yes, No]	[Yes, No]
Rate Table(s)	[Rate Table Number(s)]	[Rate Table Number(s)]	[Rate Table Number(s)]
Carrier(s) Providing	[Carrier ID(s)]	[Carrier ID(s)]	[Carrier ID(s)]

**SOHCN Facility Response Tables**

<b>SOHCN Entity</b>	Highland District Hospital	Highland District Hospital	Highland District Hospital
<b>SOHCN Facility</b>	Highland Family Medicine	Highland Pediatric Services	Community Health Clinic
<b>SOHCN Facility ID</b>	1070	1071	1072
Address	1487 N. High St, Ste. 100	1487 N. High St, Ste. 102	1440 N. High St.
City/State	Hillsboro, OH	Hillsboro, OH	Hillsboro, OH
NPA-nxx	937-847	937-393	937-840
Class of Facility	3	3	3
Primary Entry?	[Yes, Build]	[Yes, Build]	[Yes, Build]
Number of Fiber Strands	[Quantity]	[Quantity]	[Quantity]
Number of Copper Conductors	[Quantity]	[Quantity]	[Quantity]
Provisioning Cost-Primary	[Dollar Amount]	[Dollar Amount]	[Dollar Amount]
Diverse Entry?	[Yes, Build]	[Yes, Build]	[Yes, Build]
Number of Fiber Strands	[Quantity]	[Quantity]	[Quantity]
Number of Copper Conductors	[Quantity]	[Quantity]	[Quantity]
Diverse Route to POP?	[Yes, Build]	[Yes, Build]	[Yes, Build]
Diversity Method	[A, B, C, Other]	[A, B, C, Other]	[A, B, C, Other]
Provisioning Cost-Diverse	[Dollar Amount]	[Dollar Amount]	[Dollar Amount]
<b>Dedicated Services?</b>	[Yes, No]	[Yes, No]	[Yes, No]
Rate Table(s)	[Rate Table Number(s)]	[Rate Table Number(s)]	[Rate Table Number(s)]
Carrier(s) Providing	[Carrier ID(s)]	[Carrier ID(s)]	[Carrier ID(s)]
<b>Shared Services?</b>	[Yes, No]	[Yes, No]	[Yes, No]
Rate Table(s)	[Rate Table Number(s)]	[Rate Table Number(s)]	[Rate Table Number(s)]
Carrier(s) Providing	[Carrier ID(s)]	[Carrier ID(s)]	[Carrier ID(s)]

**SOHCN Facility Response Tables**

<b>SOHCN Entity</b>	Highland District Hospital	Highland District Hospital	Highland District Hospital
<b>SOHCN Facility</b>	Greenfield Medical Services	Lynchburg Medical Center	Physicians for Women Association
<b>SOHCN Facility ID</b>	1073	1074	1075
Address	1092 W. Jefferson St.	8900 SR 134	1121 Northview Dr, Ste 1
City/State	Greenfield, OH	Lynchburg, OH	Hillsboro, OH
NPA-nxx	937-981	937-364	937-393
Class of Facility	3	3	3
Primary Entry?	[Yes, Build]	[Yes, Build]	[Yes, Build]
Number of Fiber Strands	[Quantity]	[Quantity]	[Quantity]
Number of Copper Conductors	[Quantity]	[Quantity]	[Quantity]
Provisioning Cost-Primary	[Dollar Amount]	[Dollar Amount]	[Dollar Amount]
Diverse Entry?	[Yes, Build]	[Yes, Build]	[Yes, Build]
Number of Fiber Strands	[Quantity]	[Quantity]	[Quantity]
Number of Copper Conductors	[Quantity]	[Quantity]	[Quantity]
Diverse Route to POP?	[Yes, Build]	[Yes, Build]	[Yes, Build]
Diversity Method	[A, B, C, Other]	[A, B, C, Other]	[A, B, C, Other]
Provisioning Cost-Diverse	[Dollar Amount]	[Dollar Amount]	[Dollar Amount]
<b>Dedicated Services?</b>	[Yes, No]	[Yes, No]	[Yes, No]
Rate Table(s)	Rate Table Number(s)	Rate Table Number(s)	Rate Table Number(s)
Carrier(s) Providing	[Carrier ID(s)]	[Carrier ID(s)]	[Carrier ID(s)]
<b>Shared Services?</b>	[Yes, No]	[Yes, No]	[Yes, No]
Rate Table(s)	Rate Table Number(s)	Rate Table Number(s)	Rate Table Number(s)
Carrier(s) Providing	[Carrier ID(s)]	[Carrier ID(s)]	[Carrier ID(s)]

**SOHCN Facility Response Tables**

<b>SOHCN Entity</b>	Highland District Hospital	Highland District Hospital	Highland County CAO
<b>SOHCN Facility</b>	Highland Neurology	South Central Psychology	Family Health Services
<b>SOHCN Facility ID</b>	1076	1077	1078
Address	1121 Northview Dr, Ste 2	1121 Northview Dr, Ste 2	1487 N. High St.
City/State	Hillsboro, OH	Hillsboro, OH	Hillsboro, OH
NPA-nxx	937-393	937-393	937-393
Class of Facility	3	3	3
Primary Entry?	[Yes, Build]	[Yes, Build]	[Yes, Build]
Number of Fiber Strands	[Quantity]	[Quantity]	[Quantity]
Number of Copper Conductors	[Quantity]	[Quantity]	[Quantity]
Provisioning Cost-Primary	[Dollar Amount]	[Dollar Amount]	[Dollar Amount]
Diverse Entry?	[Yes, Build]	[Yes, Build]	[Yes, Build]
Number of Fiber Strands	[Quantity]	[Quantity]	[Quantity]
Number of Copper Conductors	[Quantity]	[Quantity]	[Quantity]
Diverse Route to POP?	[Yes, Build]	[Yes, Build]	[Yes, Build]
Diversity Method	[A, B, C, Other]	[A, B, C, Other]	[A, B, C, Other]
Provisioning Cost-Diverse	[Dollar Amount]	[Dollar Amount]	[Dollar Amount]
<b>Dedicated Services?</b>	[Yes, No]	[Yes, No]	[Yes, No]
Rate Table(s)	Rate Table Number(s)	Rate Table Number(s)	Rate Table Number(s)
Carrier(s) Providing	[Carrier ID(s)]	[Carrier ID(s)]	[Carrier ID(s)]
<b>Shared Services?</b>	[Yes, No]	[Yes, No]	[Yes, No]
Rate Table(s)	Rate Table Number(s)	Rate Table Number(s)	Rate Table Number(s)
Carrier(s) Providing	[Carrier ID(s)]	[Carrier ID(s)]	[Carrier ID(s)]

**SOHCN Facility Response Tables**

<b>SOHCN Entity</b>	Highland County CAO	Holzer Clinics	Holzer Clinics
<b>SOHCN Facility</b>	Greenfield Outreach	Main Clinic	Athens Clinic
<b>SOHCN Facility ID</b>	1079	1080	1081
Address	348 South St.	90 Jackson Pike	224 Columbus Rd.
City/State	Greenfield, OH	Gallipolis, OH	Athens, OH
NPA-nxx	937-981	740-446	740-589
Class of Facility	3	3	2
Primary Entry?	[Yes, Build]	[Yes, Build]	[Yes, Build]
Number of Fiber Strands	[Quantity]	[Quantity]	[Quantity]
Number of Copper Conductors	[Quantity]	[Quantity]	[Quantity]
Provisioning Cost-Primary	[Dollar Amount]	[Dollar Amount]	[Dollar Amount]
Diverse Entry?	[Yes, Build]	[Yes, Build]	[Yes, Build]
Number of Fiber Strands	[Quantity]	[Quantity]	[Quantity]
Number of Copper Conductors	[Quantity]	[Quantity]	[Quantity]
Diverse Route to POP?	[Yes, Build]	[Yes, Build]	[Yes, Build]
Diversity Method	[A, B, C, Other]	[A, B, C, Other]	[A, B, C, Other]
Provisioning Cost-Diverse	[Dollar Amount]	[Dollar Amount]	[Dollar Amount]
<b>Dedicated Services?</b>	[Yes, No]	[Yes, No]	[Yes, No]
Rate Table(s)	Rate Table Number(s)	Rate Table Number(s)	Rate Table Number(s)
Carrier(s) Providing	[Carrier ID(s)]	[Carrier ID(s)]	[Carrier ID(s)]
<b>Shared Services?</b>	[Yes, No]	[Yes, No]	[Yes, No]
Rate Table(s)	Rate Table Number(s)	Rate Table Number(s)	Rate Table Number(s)
Carrier(s) Providing	[Carrier ID(s)]	[Carrier ID(s)]	[Carrier ID(s)]

**SOHCN Facility Response Tables**

<b>SOHCN Entity</b>	Holzer Clinics	Holzer Clinics	Holzer Clinics
<b>SOHCN Facility</b>	Sycamore Clinic	Jackson Clinic	Lawrence County Clinic
<b>SOHCN Facility ID</b>	1082	1083	1084
Address	1051 4th Ave.	280 Pattonville Rd.	98 State St.
City/State	Gallipolis, OH	Jackson, OH	Proctorville, OH
NPA-nxx	740-446	740-395	740-886
Class of Facility	3	2	3
Primary Entry?	[Yes, Build]	[Yes, Build]	[Yes, Build]
Number of Fiber Strands	[Quantity]	[Quantity]	[Quantity]
Number of Copper Conductors	[Quantity]	[Quantity]	[Quantity]
Provisioning Cost-Primary	[Dollar Amount]	[Dollar Amount]	[Dollar Amount]
Diverse Entry?	[Yes, Build]	[Yes, Build]	[Yes, Build]
Number of Fiber Strands	[Quantity]	[Quantity]	[Quantity]
Number of Copper Conductors	[Quantity]	[Quantity]	[Quantity]
Diverse Route to POP?	[Yes, Build]	[Yes, Build]	[Yes, Build]
Diversity Method	[A, B, C, Other]	[A, B, C, Other]	[A, B, C, Other]
Provisioning Cost-Diverse	[Dollar Amount]	[Dollar Amount]	[Dollar Amount]
<b>Dedicated Services?</b>	[Yes, No]	[Yes, No]	[Yes, No]
Rate Table(s)	[Rate Table Number(s)]	[Rate Table Number(s)]	[Rate Table Number(s)]
Carrier(s) Providing	[Carrier ID(s)]	[Carrier ID(s)]	[Carrier ID(s)]
<b>Shared Services?</b>	[Yes, No]	[Yes, No]	[Yes, No]
Rate Table(s)	[Rate Table Number(s)]	[Rate Table Number(s)]	[Rate Table Number(s)]
Carrier(s) Providing	[Carrier ID(s)]	[Carrier ID(s)]	[Carrier ID(s)]

**SOHCN Facility Response Tables**

<b>SOHCN Entity</b>	Holzer Clinics	Holzer Clinics	Holzer Clinics
<b>SOHCN Facility</b>	Liberty Circle Clinic	Meigs County Clinic	Dr. Hojat
<b>SOHCN Facility ID</b>	1085	1086	1087
Address	96 Twp. Rd. 369, Ste. 101	88 E. Memorial Dr.	225 Country Ln.
City/State	Proctorville, OH	Pomeroy, OH	Gallipolis, OH
NPA-nxx	740-886	740-992	
Class of Facility	3	3	4
Primary Entry?	[Yes, Build]	[Yes, Build]	[Yes, Build]
Number of Fiber Strands	[Quantity]	[Quantity]	[Quantity]
Number of Copper Conductors	[Quantity]	[Quantity]	[Quantity]
Provisioning Cost-Primary	[Dollar Amount]	[Dollar Amount]	[Dollar Amount]
Diverse Entry?	[Yes, Build]	[Yes, Build]	[Yes, Build]
Number of Fiber Strands	[Quantity]	[Quantity]	[Quantity]
Number of Copper Conductors	[Quantity]	[Quantity]	[Quantity]
Diverse Route to POP?	[Yes, Build]	[Yes, Build]	[Yes, Build]
Diversity Method	[A, B, C, Other]	[A, B, C, Other]	[A, B, C, Other]
Provisioning Cost-Diverse	[Dollar Amount]	[Dollar Amount]	[Dollar Amount]
<b>Dedicated Services?</b>	[Yes, No]	[Yes, No]	[Yes, No]
Rate Table(s)	[Rate Table Number(s)]	[Rate Table Number(s)]	[Rate Table Number(s)]
Carrier(s) Providing	[Carrier ID(s)]	[Carrier ID(s)]	[Carrier ID(s)]
<b>Shared Services?</b>	[Yes, No]	[Yes, No]	[Yes, No]
Rate Table(s)	[Rate Table Number(s)]	[Rate Table Number(s)]	[Rate Table Number(s)]
Carrier(s) Providing	[Carrier ID(s)]	[Carrier ID(s)]	[Carrier ID(s)]

**SOHCN Facility Response Tables**

<b>SOHCN Entity</b>	Holzer Clinics	Holzer Clinics	Holzer Clinics
<b>SOHCN Facility</b>	Dr. Casanova	Dr. Pennington	Dr. Myers
<b>SOHCN Facility ID</b>	1088	1089	1090
Address	745 Buhl Morton Rd.	563 Juniper Ln.	560 Juniper Ln.
City/State	Gallipolis, OH	Gallipolis, OH	Gallipolis, OH
NPA-nxx			
Class of Facility	4	4	4
Primary Entry?	[Yes, Build]	[Yes, Build]	[Yes, Build]
Number of Fiber Strands	[Quantity]	[Quantity]	[Quantity]
Number of Copper Conductors	[Quantity]	[Quantity]	[Quantity]
Provisioning Cost-Primary	[Dollar Amount]	[Dollar Amount]	[Dollar Amount]
Diverse Entry?	[Yes, Build]	[Yes, Build]	[Yes, Build]
Number of Fiber Strands	[Quantity]	[Quantity]	[Quantity]
Number of Copper Conductors	[Quantity]	[Quantity]	[Quantity]
Diverse Route to POP?	[Yes, Build]	[Yes, Build]	[Yes, Build]
Diversity Method	[A, B, C, Other]	[A, B, C, Other]	[A, B, C, Other]
Provisioning Cost-Diverse	[Dollar Amount]	[Dollar Amount]	[Dollar Amount]
<b>Dedicated Services?</b>	[Yes, No]	[Yes, No]	[Yes, No]
Rate Table(s)	[Rate Table Number(s)]	[Rate Table Number(s)]	[Rate Table Number(s)]
Carrier(s) Providing	[Carrier ID(s)]	[Carrier ID(s)]	[Carrier ID(s)]
<b>Shared Services?</b>	[Yes, No]	[Yes, No]	[Yes, No]
Rate Table(s)	[Rate Table Number(s)]	[Rate Table Number(s)]	[Rate Table Number(s)]
Carrier(s) Providing	[Carrier ID(s)]	[Carrier ID(s)]	[Carrier ID(s)]

**SOHCN Facility Response Tables**

<b>SOHCN Entity</b>	Holzer Clinics	Holzer Clinics	Holzer Clinics
<b>SOHCN Facility</b>	Dr. Long	Dr. Price	Dr. Zamir
<b>SOHCN Facility ID</b>	1091	1092	1093
Address	212 Laurel Rd.	1043 Duly Rd.	45 Crestview
City/State	Gallipolis, OH	Gallipolis, OH	Gallipolis, OH
NPA-nxx			
Class of Facility	4	4	4
Primary Entry?	[Yes, Build]	[Yes, Build]	[Yes, Build]
Number of Fiber Strands	[Quantity]	[Quantity]	[Quantity]
Number of Copper Conductors	[Quantity]	[Quantity]	[Quantity]
Provisioning Cost-Primary	[Dollar Amount]	[Dollar Amount]	[Dollar Amount]
Diverse Entry?	[Yes, Build]	[Yes, Build]	[Yes, Build]
Number of Fiber Strands	[Quantity]	[Quantity]	[Quantity]
Number of Copper Conductors	[Quantity]	[Quantity]	[Quantity]
Diverse Route to POP?	[Yes, Build]	[Yes, Build]	[Yes, Build]
Diversity Method	[A, B, C, Other]	[A, B, C, Other]	[A, B, C, Other]
Provisioning Cost-Diverse	[Dollar Amount]	[Dollar Amount]	[Dollar Amount]
<b>Dedicated Services?</b>	[Yes, No]	[Yes, No]	[Yes, No]
Rate Table(s)	[Rate Table Number(s)]	[Rate Table Number(s)]	[Rate Table Number(s)]
Carrier(s) Providing	[Carrier ID(s)]	[Carrier ID(s)]	[Carrier ID(s)]
<b>Shared Services?</b>	[Yes, No]	[Yes, No]	[Yes, No]
Rate Table(s)	[Rate Table Number(s)]	[Rate Table Number(s)]	[Rate Table Number(s)]
Carrier(s) Providing	[Carrier ID(s)]	[Carrier ID(s)]	[Carrier ID(s)]

**SOHCN Facility Response Tables**

<b>SOHCN Entity</b>	Holzer Clinics	HealthSource of Ohio	HealthSource of Ohio
<b>SOHCN Facility</b>	Dr. Siciliano	Seaman Health Center	Greenfield Family Practice
<b>SOHCN Facility ID</b>	1094	1095	1096
Address	412 Woodsmill Rd.	218 Stern Dr.	1075 N. Washington St.
City/State	Bidwell, OH	Seaman, OH	Greenfield, OH
NPA-nxx		937-386	937-981
Class of Facility	4	3	3
Primary Entry?	[Yes, Build]	[Yes, Build]	[Yes, Build]
Number of Fiber Strands	[Quantity]	[Quantity]	[Quantity]
Number of Copper Conductors	[Quantity]	[Quantity]	[Quantity]
Provisioning Cost-Primary	[Dollar Amount]	[Dollar Amount]	[Dollar Amount]
Diverse Entry?	[Yes, Build]	[Yes, Build]	[Yes, Build]
Number of Fiber Strands	[Quantity]	[Quantity]	[Quantity]
Number of Copper Conductors	[Quantity]	[Quantity]	[Quantity]
Diverse Route to POP?	[Yes, Build]	[Yes, Build]	[Yes, Build]
Diversity Method	[A, B, C, Other]	[A, B, C, Other]	[A, B, C, Other]
Provisioning Cost-Diverse	[Dollar Amount]	[Dollar Amount]	[Dollar Amount]
<b>Dedicated Services?</b>	[Yes, No]	[Yes, No]	[Yes, No]
Rate Table(s)	[Rate Table Number(s)]	[Rate Table Number(s)]	[Rate Table Number(s)]
Carrier(s) Providing	[Carrier ID(s)]	[Carrier ID(s)]	[Carrier ID(s)]
<b>Shared Services?</b>	[Yes, No]	[Yes, No]	[Yes, No]
Rate Table(s)	[Rate Table Number(s)]	[Rate Table Number(s)]	[Rate Table Number(s)]
Carrier(s) Providing	[Carrier ID(s)]	[Carrier ID(s)]	[Carrier ID(s)]

**SOHCN Facility Response Tables**

<b>SOHCN Entity</b>	HealthSource of Ohio	HealthSource of Ohio	Fayette County Memorial Hospital
<b>SOHCN Facility</b>	Hillsboro Health Center	Washington Court House Family	Fayette County Memorial Hospital
<b>SOHCN Facility ID</b>	1097	1098	1099
Address	104 Erin Ct.	1450 Columbus Ave, Ste. 203	1430 Columbus Ave.
City/State	Hillsboro, OH	Washington Court House, OH	Washington Court House, OH
NPA-nxx	937-939	740-335	740-335
Class of Facility	3	3	2
Primary Entry?	[Yes, Build]	[Yes, Build]	[Yes, Build]
Number of Fiber Strands	[Quantity]	[Quantity]	[Quantity]
Number of Copper Conductors	[Quantity]	[Quantity]	[Quantity]
Provisioning Cost-Primary	[Dollar Amount]	[Dollar Amount]	[Dollar Amount]
Diverse Entry?	[Yes, Build]	[Yes, Build]	[Yes, Build]
Number of Fiber Strands	[Quantity]	[Quantity]	[Quantity]
Number of Copper Conductors	[Quantity]	[Quantity]	[Quantity]
Diverse Route to POP?	[Yes, Build]	[Yes, Build]	[Yes, Build]
Diversity Method	[A, B, C, Other]	[A, B, C, Other]	[A, B, C, Other]
Provisioning Cost-Diverse	[Dollar Amount]	[Dollar Amount]	[Dollar Amount]
<b>Dedicated Services?</b>	[Yes, No]	[Yes, No]	[Yes, No]
Rate Table(s)	[Rate Table Number(s)]	[Rate Table Number(s)]	[Rate Table Number(s)]
Carrier(s) Providing	[Carrier ID(s)]	[Carrier ID(s)]	[Carrier ID(s)]
<b>Shared Services?</b>	[Yes, No]	[Yes, No]	[Yes, No]
Rate Table(s)	[Rate Table Number(s)]	[Rate Table Number(s)]	[Rate Table Number(s)]
Carrier(s) Providing	[Carrier ID(s)]	[Carrier ID(s)]	[Carrier ID(s)]

**SOHCN Facility Response Tables**

<b>SOHCN Entity</b>	Dr. DiTraglia Pediatrics	Southern Ohio Medical Center	Adams Brown Counties Economic
<b>SOHCN Facility</b>	Dr. DiTraglia Pediatrics	Southern Ohio Medical Center	Family Health Clinic
<b>SOHCN Facility ID</b>	1100	1101	1102
Address	717 5th St.	1805 27th St.	9137 SR 136
City/State	Portsmouth, OH	Portsmouth, OH	West Union, OH
NPA-nxx	740-354	740-356	937-544
Class of Facility	3	1	3
Primary Entry?	[Yes, Build]	[Yes, Build]	[Yes, Build]
Number of Fiber Strands	[Quantity]	[Quantity]	[Quantity]
Number of Copper Conductors	[Quantity]	[Quantity]	[Quantity]
Provisioning Cost-Primary	[Dollar Amount]	[Dollar Amount]	[Dollar Amount]
Diverse Entry?	[Yes, Build]	[Yes, Build]	[Yes, Build]
Number of Fiber Strands	[Quantity]	[Quantity]	[Quantity]
Number of Copper Conductors	[Quantity]	[Quantity]	[Quantity]
Diverse Route to POP?	[Yes, Build]	[Yes, Build]	[Yes, Build]
Diversity Method	[A, B, C, Other]	[A, B, C, Other]	[A, B, C, Other]
Provisioning Cost-Diverse	[Dollar Amount]	[Dollar Amount]	[Dollar Amount]
<b>Dedicated Services?</b>	[Yes, No]	[Yes, No]	[Yes, No]
Rate Table(s)	[Rate Table Number(s)]	[Rate Table Number(s)]	[Rate Table Number(s)]
Carrier(s) Providing	[Carrier ID(s)]	[Carrier ID(s)]	[Carrier ID(s)]
<b>Shared Services?</b>	[Yes, No]	[Yes, No]	[Yes, No]
Rate Table(s)	[Rate Table Number(s)]	[Rate Table Number(s)]	[Rate Table Number(s)]
Carrier(s) Providing	[Carrier ID(s)]	[Carrier ID(s)]	[Carrier ID(s)]

**SOHCN Facility Response Tables**

<b>SOHCN Entity</b>	Adams Brown Counties Economic	Tri County Mental Health & Counseling	Tri County Mental Health & Counseling
<b>SOHCN Facility</b>	Intake Office	Athens County Clinic	Crisis Stabilization Unit
<b>SOHCN Facility ID</b>	1103	1104	1105
Address	19211 Main St.	90 Hospital Dr.	7976 Dairy Ln.
City/State	Winchester, OH	Athens, OH	Athens, OH
NPA-nxx	937-695	740-594	740-592
Class of Facility	3	3	2
Primary Entry?	[Yes, Build]	[Yes, Build]	[Yes, Build]
Number of Fiber Strands	[Quantity]	[Quantity]	[Quantity]
Number of Copper Conductors	[Quantity]	[Quantity]	[Quantity]
Provisioning Cost-Primary	[Dollar Amount]	[Dollar Amount]	[Dollar Amount]
Diverse Entry?	[Yes, Build]	[Yes, Build]	[Yes, Build]
Number of Fiber Strands	[Quantity]	[Quantity]	[Quantity]
Number of Copper Conductors	[Quantity]	[Quantity]	[Quantity]
Diverse Route to POP?	[Yes, Build]	[Yes, Build]	[Yes, Build]
Diversity Method	[A, B, C, Other]	[A, B, C, Other]	[A, B, C, Other]
Provisioning Cost-Diverse	[Dollar Amount]	[Dollar Amount]	[Dollar Amount]
<b>Dedicated Services?</b>	[Yes, No]	[Yes, No]	[Yes, No]
Rate Table(s)	[Rate Table Number(s)]	[Rate Table Number(s)]	[Rate Table Number(s)]
Carrier(s) Providing	[Carrier ID(s)]	[Carrier ID(s)]	[Carrier ID(s)]
<b>Shared Services?</b>	[Yes, No]	[Yes, No]	[Yes, No]
Rate Table(s)	[Rate Table Number(s)]	[Rate Table Number(s)]	[Rate Table Number(s)]
Carrier(s) Providing	[Carrier ID(s)]	[Carrier ID(s)]	[Carrier ID(s)]

**SOHCN Facility Response Tables**

<b>SOHCN Entity</b>	Tri County Mental Health & Counseling	Tri County Mental Health & Counseling	O'Bleness Health System
<b>SOHCN Facility</b>	Vinton County Clinic	REACH	O'Bleness Memorial Hospital
<b>SOHCN Facility ID</b>	1106	1107	1108
Address	313 1/2 W. Main St.	817 W. Union St.	55 Hospital Dr.
City/State	McArthur, OH	Athens, OH	Athens, OH
NPA-nxx	740-596	740-589	740-593
Class of Facility	3	3	1
Primary Entry?	[Yes, Build]	[Yes, Build]	[Yes, Build]
Number of Fiber Strands	[Quantity]	[Quantity]	[Quantity]
Number of Copper Conductors	[Quantity]	[Quantity]	[Quantity]
Provisioning Cost-Primary	[Dollar Amount]	[Dollar Amount]	[Dollar Amount]
Diverse Entry?	[Yes, Build]	[Yes, Build]	[Yes, Build]
Number of Fiber Strands	[Quantity]	[Quantity]	[Quantity]
Number of Copper Conductors	[Quantity]	[Quantity]	[Quantity]
Diverse Route to POP?	[Yes, Build]	[Yes, Build]	[Yes, Build]
Diversity Method	[A, B, C, Other]	[A, B, C, Other]	[A, B, C, Other]
Provisioning Cost-Diverse	[Dollar Amount]	[Dollar Amount]	[Dollar Amount]
<b>Dedicated Services?</b>	[Yes, No]	[Yes, No]	[Yes, No]
Rate Table(s)	Rate Table Number(s)	Rate Table Number(s)	Rate Table Number(s)
Carrier(s) Providing	[Carrier ID(s)]	[Carrier ID(s)]	[Carrier ID(s)]
<b>Shared Services?</b>	[Yes, No]	[Yes, No]	[Yes, No]
Rate Table(s)	Rate Table Number(s)	Rate Table Number(s)	Rate Table Number(s)
Carrier(s) Providing	[Carrier ID(s)]	[Carrier ID(s)]	[Carrier ID(s)]

<b>SOHCN Entity</b>	O'Bleness Health System	O'Bleness Health System	O'Bleness Health System
<b>SOHCN Facility</b>	Meigs Medical Clinic	Family Practice Clinic	Albany Medical Clinic
<b>SOHCN Facility ID</b>	1109	1110	1111
Address	113 E. Memorial Dr.	444 W. Union St, Ste E	2364 Blizzard Ln.
City/State	Pomeroy, OH	Athens, OH	Albany, OH
NPA-nxx	740-992	740-566	740-698
Class of Facility	3	3	3
Primary Entry?	[Yes, Build]	[Yes, Build]	[Yes, Build]
Number of Fiber Strands	[Quantity]	[Quantity]	[Quantity]
Number of Copper Conductors	[Quantity]	[Quantity]	[Quantity]
Provisioning Cost-Primary	[Dollar Amount]	[Dollar Amount]	[Dollar Amount]
Diverse Entry?	[Yes, Build]	[Yes, Build]	[Yes, Build]
Number of Fiber Strands	[Quantity]	[Quantity]	[Quantity]
Number of Copper Conductors	[Quantity]	[Quantity]	[Quantity]
Diverse Route to POP?	[Yes, Build]	[Yes, Build]	[Yes, Build]
Diversity Method	[A, B, C, Other]	[A, B, C, Other]	[A, B, C, Other]
Provisioning Cost-Diverse	[Dollar Amount]	[Dollar Amount]	[Dollar Amount]

**SOHCN Facility Response Tables**

<b>Dedicated Services?</b>	[Yes, No]	[Yes, No]	[Yes, No]
Rate Table(s)	Rate Table Number(s)	Rate Table Number(s)	Rate Table Number(s)
Carrier(s) Providing	Carrier ID(s)	Carrier ID(s)	Carrier ID(s)
<b>Shared Services?</b>	[Yes, No]	[Yes, No]	[Yes, No]
Rate Table(s)	Rate Table Number(s)	Rate Table Number(s)	Rate Table Number(s)
Carrier(s) Providing	Carrier ID(s)	Carrier ID(s)	Carrier ID(s)

**SOHCN Facility Response Tables**

<b>SOHCN Entity</b>	O'Bleness Health System	O'Bleness Health System	O'Bleness Health System
<b>SOHCN Facility</b>	Dermatology Clinic	Women's Clinic	Appalachian Community Visiting
<b>SOHCN Facility ID</b>	1112	1113	1114
Address	75 Hospital Dr, Ste. 230	75 Hospital Dr, Ste. 330	30 Herrold Ave.
City/State	Athens, OH	Athens, OH	Athens, OH
NPA-nxx	740-566	740-566	740-594
Class of Facility	3	3	3
Primary Entry?	[Yes, Build]	[Yes, Build]	[Yes, Build]
Number of Fiber Strands	[Quantity]	[Quantity]	[Quantity]
Number of Copper Conductors	[Quantity]	[Quantity]	[Quantity]
Provisioning Cost-Primary	[Dollar Amount]	[Dollar Amount]	[Dollar Amount]
Diverse Entry?	[Yes, Build]	[Yes, Build]	[Yes, Build]
Number of Fiber Strands	[Quantity]	[Quantity]	[Quantity]
Number of Copper Conductors	[Quantity]	[Quantity]	[Quantity]
Diverse Route to POP?	[Yes, Build]	[Yes, Build]	[Yes, Build]
Diversity Method	[A, B, C, Other]	[A, B, C, Other]	[A, B, C, Other]
Provisioning Cost-Diverse	[Dollar Amount]	[Dollar Amount]	[Dollar Amount]
<b>Dedicated Services?</b>	[Yes, No]	[Yes, No]	[Yes, No]
Rate Table(s)	Rate Table Number(s)	Rate Table Number(s)	Rate Table Number(s)
Carrier(s) Providing	[Carrier ID(s)]	[Carrier ID(s)]	[Carrier ID(s)]
<b>Shared Services?</b>	[Yes, No]	[Yes, No]	[Yes, No]
Rate Table(s)	Rate Table Number(s)	Rate Table Number(s)	Rate Table Number(s)
Carrier(s) Providing	[Carrier ID(s)]	[Carrier ID(s)]	[Carrier ID(s)]

**SOHCN Facility Response Tables**

<b>SOHCN Entity</b>	Bleness Health System	Bleness Health System	Bleness Health System
<b>SOHCN Facility</b>	Medical Lab	OB-GYN	Surgery Center
<b>SOHCN Facility ID</b>	1115	1116	1117
Address	400 E. State St.	86 Columbus Rd, Ste. 203	75 Hospital Dr, Ste. 100
City/State	Athens, OH	Athens, OH	Athens, OH
NPA-nxx	740-593	740-594	740-566
Class of Facility	3	3	3
Primary Entry?	[Yes, Build]	[Yes, Build]	[Yes, Build]
Number of Fiber Strands	[Quantity]	[Quantity]	[Quantity]
Number of Copper Conductors	[Quantity]	[Quantity]	[Quantity]
Provisioning Cost-Primary	[Dollar Amount]	[Dollar Amount]	[Dollar Amount]
Diverse Entry?	[Yes, Build]	[Yes, Build]	[Yes, Build]
Number of Fiber Strands	[Quantity]	[Quantity]	[Quantity]
Number of Copper Conductors	[Quantity]	[Quantity]	[Quantity]
Diverse Route to POP?	[Yes, Build]	[Yes, Build]	[Yes, Build]
Diversity Method	[A, B, C, Other]	[A, B, C, Other]	[A, B, C, Other]
Provisioning Cost-Diverse	[Dollar Amount]	[Dollar Amount]	[Dollar Amount]
<b>Dedicated Services?</b>	[Yes, No]	[Yes, No]	[Yes, No]
Rate Table(s)	[Rate Table Number(s)]	[Rate Table Number(s)]	[Rate Table Number(s)]
Carrier(s) Providing	[Carrier ID(s)]	[Carrier ID(s)]	[Carrier ID(s)]
<b>Shared Services?</b>	[Yes, No]	[Yes, No]	[Yes, No]
Rate Table(s)	[Rate Table Number(s)]	[Rate Table Number(s)]	[Rate Table Number(s)]
Carrier(s) Providing	[Carrier ID(s)]	[Carrier ID(s)]	[Carrier ID(s)]

**SOHCN Facility Response Tables**

<b>SOHCN Entity</b>	O'Bleness Health System	O'Bleness Health System	O'Bleness Health System
<b>SOHCN Facility</b>	Urologic Care	Health First Care Center	River Rose OB-GYN
<b>SOHCN Facility ID</b>	1118	1119	1120
Address	265 W. Union St.	75 Hospital Dr, Ste. 200	75 Hospital Dr, Ste. 260
City/State	Athens, OH	Athens, OH	Athens, OH
NPA-nxx	740-594	740-594	740-594
Class of Facility	3	3	3
Primary Entry?	[Yes, Build]	[Yes, Build]	[Yes, Build]
Number of Fiber Strands	[Quantity]	[Quantity]	[Quantity]
Number of Copper Conductors	[Quantity]	[Quantity]	[Quantity]
Provisioning Cost-Primary	[Dollar Amount]	[Dollar Amount]	[Dollar Amount]
Diverse Entry?	[Yes, Build]	[Yes, Build]	[Yes, Build]
Number of Fiber Strands	[Quantity]	[Quantity]	[Quantity]
Number of Copper Conductors	[Quantity]	[Quantity]	[Quantity]
Diverse Route to POP?	[Yes, Build]	[Yes, Build]	[Yes, Build]
Diversity Method	[A, B, C, Other]	[A, B, C, Other]	[A, B, C, Other]
Provisioning Cost-Diverse	[Dollar Amount]	[Dollar Amount]	[Dollar Amount]
<b>Dedicated Services?</b>	[Yes, No]	[Yes, No]	[Yes, No]
Rate Table(s)	[Rate Table Number(s)]	[Rate Table Number(s)]	[Rate Table Number(s)]
Carrier(s) Providing	[Carrier ID(s)]	[Carrier ID(s)]	[Carrier ID(s)]
<b>Shared Services?</b>	[Yes, No]	[Yes, No]	[Yes, No]
Rate Table(s)	[Rate Table Number(s)]	[Rate Table Number(s)]	[Rate Table Number(s)]
Carrier(s) Providing	[Carrier ID(s)]	[Carrier ID(s)]	[Carrier ID(s)]

**SOHCN Facility Response Tables**

<b>SOHCN Entity</b>	O'Bleness Health System	O'Bleness Health System	O'Bleness Health System
<b>SOHCN Facility</b>	The Drugstore	Hunter Family Practice	Dr. Murrey
<b>SOHCN Facility ID</b>	1121	1122	1123
Address	75 Hospital Dr, Ste. 130	207 5th St.	486 Longview Heights
City/State	Athens, OH	Racine, OH	Athens, OH
NPA-nxx	740-566	740-949	
Class of Facility	3	3	4
Primary Entry?	[Yes, Build]	[Yes, Build]	[Yes, Build]
Number of Fiber Strands	[Quantity]	[Quantity]	[Quantity]
Number of Copper Conductors	[Quantity]	[Quantity]	[Quantity]
Provisioning Cost-Primary	[Dollar Amount]	[Dollar Amount]	[Dollar Amount]
Diverse Entry?	[Yes, Build]	[Yes, Build]	[Yes, Build]
Number of Fiber Strands	[Quantity]	[Quantity]	[Quantity]
Number of Copper Conductors	[Quantity]	[Quantity]	[Quantity]
Diverse Route to POP?	[Yes, Build]	[Yes, Build]	[Yes, Build]
Diversity Method	[A, B, C, Other]	[A, B, C, Other]	[A, B, C, Other]
Provisioning Cost-Diverse	[Dollar Amount]	[Dollar Amount]	[Dollar Amount]
<b>Dedicated Services?</b>	[Yes, No]	[Yes, No]	[Yes, No]
Rate Table(s)	Rate Table Number(s)	Rate Table Number(s)	Rate Table Number(s)
Carrier(s) Providing	[Carrier ID(s)]	[Carrier ID(s)]	[Carrier ID(s)]
<b>Shared Services?</b>	[Yes, No]	[Yes, No]	[Yes, No]
Rate Table(s)	Rate Table Number(s)	Rate Table Number(s)	Rate Table Number(s)
Carrier(s) Providing	[Carrier ID(s)]	[Carrier ID(s)]	[Carrier ID(s)]

**SOHCN Facility Response Tables**

<b>SOHCN Entity</b>	O'Bleness Health System	O'Bleness Health System	Jackson-Vinton Community Action,
<b>SOHCN Facility</b>	Dr. Benseler	Dr. Roberts	Health Services
<b>SOHCN Facility ID</b>	1124	1125	1126
Address	14 Windsong Ln.	5466 Pleasant Hill	118 S. New York Ave.
City/State	Athens, OH	Athens, OH	Wellston, OH
NPA-nxx			740-384
Class of Facility	4	4	3
Primary Entry?	[Yes, Build]	[Yes, Build]	[Yes, Build]
Number of Fiber Strands	[Quantity]	[Quantity]	[Quantity]
Number of Copper Conductors	[Quantity]	[Quantity]	[Quantity]
Provisioning Cost-Primary	[Dollar Amount]	[Dollar Amount]	[Dollar Amount]
Diverse Entry?	[Yes, Build]	[Yes, Build]	[Yes, Build]
Number of Fiber Strands	[Quantity]	[Quantity]	[Quantity]
Number of Copper Conductors	[Quantity]	[Quantity]	[Quantity]
Diverse Route to POP?	[Yes, Build]	[Yes, Build]	[Yes, Build]
Diversity Method	[A, B, C, Other]	[A, B, C, Other]	[A, B, C, Other]
Provisioning Cost-Diverse	[Dollar Amount]	[Dollar Amount]	[Dollar Amount]
<b>Dedicated Services?</b>	[Yes, No]	[Yes, No]	[Yes, No]
Rate Table(s)	Rate Table Number(s)	Rate Table Number(s)	Rate Table Number(s)
Carrier(s) Providing	[Carrier ID(s)]	[Carrier ID(s)]	[Carrier ID(s)]
<b>Shared Services?</b>	[Yes, No]	[Yes, No]	[Yes, No]
Rate Table(s)	Rate Table Number(s)	Rate Table Number(s)	Rate Table Number(s)
Carrier(s) Providing	[Carrier ID(s)]	[Carrier ID(s)]	[Carrier ID(s)]

**SOHCN Facility Response Tables**

<b>SOHCN Entity</b>	Ohio Department of Health	Ohio Department of Health	Ohio Department of Health
<b>SOHCN Facility</b>	Adams County	Athens County	Fayette County
<b>SOHCN Facility ID</b>	1127	1128	1129
Address	116 W. Mulberry	278 W. Union St.	317 S. Fayette St.
City/State	West Union, OH	Athens, OH	OH
NPA-nxx	937-544	740-592	740-335
Class of Facility	3	3	3
Primary Entry?	[Yes, Build]	[Yes, Build]	[Yes, Build]
Number of Fiber Strands	[Quantity]	[Quantity]	[Quantity]
Number of Copper Conductors	[Quantity]	[Quantity]	[Quantity]
Provisioning Cost-Primary	[Dollar Amount]	[Dollar Amount]	[Dollar Amount]
Diverse Entry?	[Yes, Build]	[Yes, Build]	[Yes, Build]
Number of Fiber Strands	[Quantity]	[Quantity]	[Quantity]
Number of Copper Conductors	[Quantity]	[Quantity]	[Quantity]
Diverse Route to POP?	[Yes, Build]	[Yes, Build]	[Yes, Build]
Diversity Method	[A, B, C, Other]	[A, B, C, Other]	[A, B, C, Other]
Provisioning Cost-Diverse	[Dollar Amount]	[Dollar Amount]	[Dollar Amount]
<b>Dedicated Services?</b>	[Yes, No]	[Yes, No]	[Yes, No]
Rate Table(s)	Rate Table Number(s)	Rate Table Number(s)	Rate Table Number(s)
Carrier(s) Providing	[Carrier ID(s)]	[Carrier ID(s)]	[Carrier ID(s)]
<b>Shared Services?</b>	[Yes, No]	[Yes, No]	[Yes, No]
Rate Table(s)	Rate Table Number(s)	Rate Table Number(s)	Rate Table Number(s)
Carrier(s) Providing	[Carrier ID(s)]	[Carrier ID(s)]	[Carrier ID(s)]

**SOHCN Facility Response Tables**

<b>SOHCN Entity</b>	Ohio Department of Health	Ohio Department of Health	Ohio Department of Health
<b>SOHCN Facility</b>	Gallia County	Highland County	Jackson County
<b>SOHCN Facility ID</b>	1130	1131	1132
Address	499 Jackson Pike, Ste. D	1487 N. High St, Ste. 400	200 E. Main St.
City/State	Gallipolis, OH	Hillsboro, OH	Jackson, OH
NPA-nxx	740-441	937-393	740-286
Class of Facility	3	3	3
Primary Entry?	[Yes, Build]	[Yes, Build]	[Yes, Build]
Number of Fiber Strands	[Quantity]	[Quantity]	[Quantity]
Number of Copper Conductors	[Quantity]	[Quantity]	[Quantity]
Provisioning Cost-Primary	[Dollar Amount]	[Dollar Amount]	[Dollar Amount]
Diverse Entry?	[Yes, Build]	[Yes, Build]	[Yes, Build]
Number of Fiber Strands	[Quantity]	[Quantity]	[Quantity]
Number of Copper Conductors	[Quantity]	[Quantity]	[Quantity]
Diverse Route to POP?	[Yes, Build]	[Yes, Build]	[Yes, Build]
Diversity Method	[A, B, C, Other]	[A, B, C, Other]	[A, B, C, Other]
Provisioning Cost-Diverse	[Dollar Amount]	[Dollar Amount]	[Dollar Amount]
<b>Dedicated Services?</b>	[Yes, No]	[Yes, No]	[Yes, No]
Rate Table(s)	Rate Table Number(s)	Rate Table Number(s)	Rate Table Number(s)
Carrier(s) Providing	[Carrier ID(s)]	[Carrier ID(s)]	[Carrier ID(s)]
<b>Shared Services?</b>	[Yes, No]	[Yes, No]	[Yes, No]
Rate Table(s)	Rate Table Number(s)	Rate Table Number(s)	Rate Table Number(s)
Carrier(s) Providing	[Carrier ID(s)]	[Carrier ID(s)]	[Carrier ID(s)]

**SOHCN Facility Response Tables**

<b>SOHCN Entity</b>	Ohio Department of Health	Ohio Department of Health	Ohio Department of Health
<b>SOHCN Facility</b>	Lawrence County	Meigs County	Pike County
<b>SOHCN Facility ID</b>	1133	1134	1135
Address	2122 S. Eighth St.	112 E. Memorial Dr, Ste. A	14050 US 23 North
City/State	Ironton, OH	Pomeroy, OH	Waverly, OH
NPA-nxx	740-532	740-992	740-947
Class of Facility	3	3	3
Primary Entry?	[Yes, Build]	[Yes, Build]	[Yes, Build]
Number of Fiber Strands	[Quantity]	[Quantity]	[Quantity]
Number of Copper Conductors	[Quantity]	[Quantity]	[Quantity]
Provisioning Cost-Primary	[Dollar Amount]	[Dollar Amount]	[Dollar Amount]
Diverse Entry?	[Yes, Build]	[Yes, Build]	[Yes, Build]
Number of Fiber Strands	[Quantity]	[Quantity]	[Quantity]
Number of Copper Conductors	[Quantity]	[Quantity]	[Quantity]
Diverse Route to POP?	[Yes, Build]	[Yes, Build]	[Yes, Build]
Diversity Method	[A, B, C, Other]	[A, B, C, Other]	[A, B, C, Other]
Provisioning Cost-Diverse	[Dollar Amount]	[Dollar Amount]	[Dollar Amount]
<b>Dedicated Services?</b>	[Yes, No]	[Yes, No]	[Yes, No]
Rate Table(s)	Rate Table Number(s)	Rate Table Number(s)	Rate Table Number(s)
Carrier(s) Providing	[Carrier ID(s)]	[Carrier ID(s)]	[Carrier ID(s)]
<b>Shared Services?</b>	[Yes, No]	[Yes, No]	[Yes, No]
Rate Table(s)	Rate Table Number(s)	Rate Table Number(s)	Rate Table Number(s)
Carrier(s) Providing	[Carrier ID(s)]	[Carrier ID(s)]	[Carrier ID(s)]

**SOHCN Facility Response Tables**

<b>SOHCN Entity</b>	Ohio Department of Health	Ohio Department of Health	University Medical Associates
<b>SOHCN Facility</b>	Ross County	Vinton County	Albany Family Medicine
<b>SOHCN Facility ID</b>	1136	1137	1138
Address	475 Western Ave, Ste. 5A	31927 SR 93	2364 Blizzard Ln, Ste. C
City/State	Chillicothe, OH	McArthur, OH	Albany, OH
NPA-nxx	740-779	740-596	740-698
Class of Facility	3	3	3
Primary Entry?	[Yes, Build]	[Yes, Build]	[Yes, Build]
Number of Fiber Strands	[Quantity]	[Quantity]	[Quantity]
Number of Copper Conductors	[Quantity]	[Quantity]	[Quantity]
Provisioning Cost-Primary	[Dollar Amount]	[Dollar Amount]	[Dollar Amount]
Diverse Entry?	[Yes, Build]	[Yes, Build]	[Yes, Build]
Number of Fiber Strands	[Quantity]	[Quantity]	[Quantity]
Number of Copper Conductors	[Quantity]	[Quantity]	[Quantity]
Diverse Route to POP?	[Yes, Build]	[Yes, Build]	[Yes, Build]
Diversity Method	[A, B, C, Other]	[A, B, C, Other]	[A, B, C, Other]
Provisioning Cost-Diverse	[Dollar Amount]	[Dollar Amount]	[Dollar Amount]
<b>Dedicated Services?</b>	[Yes, No]	[Yes, No]	[Yes, No]
Rate Table(s)	Rate Table Number(s)	Rate Table Number(s)	Rate Table Number(s)
Carrier(s) Providing	[Carrier ID(s)]	[Carrier ID(s)]	[Carrier ID(s)]
<b>Shared Services?</b>	[Yes, No]	[Yes, No]	[Yes, No]
Rate Table(s)	Rate Table Number(s)	Rate Table Number(s)	Rate Table Number(s)
Carrier(s) Providing	[Carrier ID(s)]	[Carrier ID(s)]	[Carrier ID(s)]

**SOHCN Facility Response Tables**

<b>SOHCN Entity</b>	University Medical Associates	University Medical Associates	University Medical Associates
<b>SOHCN Facility</b>	Cornwell Center	Castrop Center	Parks Hall
<b>SOHCN Facility ID</b>	1139	1140	1141
Address	65 Hospital Dr.	75 Hospital Dr.	Parks Hall, Ohio University
City/State	Athens, OH	Athens, OH	Athens, OH
NPA-nxx	740-566	740-594	740-593
Class of Facility	3	3	3
Primary Entry?	[Yes, Build]	[Yes, Build]	[Yes, Build]
Number of Fiber Strands	[Quantity]	[Quantity]	[Quantity]
Number of Copper Conductors	[Quantity]	[Quantity]	[Quantity]
Provisioning Cost-Primary	[Dollar Amount]	[Dollar Amount]	[Dollar Amount]
Diverse Entry?	[Yes, Build]	[Yes, Build]	[Yes, Build]
Number of Fiber Strands	[Quantity]	[Quantity]	[Quantity]
Number of Copper Conductors	[Quantity]	[Quantity]	[Quantity]
Diverse Route to POP?	[Yes, Build]	[Yes, Build]	[Yes, Build]
Diversity Method	[A, B, C, Other]	[A, B, C, Other]	[A, B, C, Other]
Provisioning Cost-Diverse	[Dollar Amount]	[Dollar Amount]	[Dollar Amount]
<b>Dedicated Services?</b>	[Yes, No]	[Yes, No]	[Yes, No]
Rate Table(s)	[Rate Table Number(s)]	[Rate Table Number(s)]	[Rate Table Number(s)]
Carrier(s) Providing	[Carrier ID(s)]	[Carrier ID(s)]	[Carrier ID(s)]
<b>Shared Services?</b>	[Yes, No]	[Yes, No]	[Yes, No]
Rate Table(s)	[Rate Table Number(s)]	[Rate Table Number(s)]	[Rate Table Number(s)]
Carrier(s) Providing	[Carrier ID(s)]	[Carrier ID(s)]	[Carrier ID(s)]

**SOHCN Facility Response Tables**

<b>SOHCN Entity</b>	University Medical Associates	University Medical Associates	University Medical Associates
<b>SOHCN Facility</b>	Coolville Healthcare Center	Nelsonville Family Medicine	Hocking Valley Community
<b>SOHCN Facility ID</b>	1142	1143	1144
Address	25716 Wilson St.	294 Harper St.	111 West 29 Dr.
City/State	Coolville, OH	Nelsonville, OH	Nelsonville, OH
NPA-nxx	740-667	740-753	740-753
Class of Facility	3	3	3
Primary Entry?	[Yes, Build]	[Yes, Build]	[Yes, Build]
Number of Fiber Strands	[Quantity]	[Quantity]	[Quantity]
Number of Copper Conductors	[Quantity]	[Quantity]	[Quantity]
Provisioning Cost-Primary	[Dollar Amount]	[Dollar Amount]	[Dollar Amount]
Diverse Entry?	[Yes, Build]	[Yes, Build]	[Yes, Build]
Number of Fiber Strands	[Quantity]	[Quantity]	[Quantity]
Number of Copper Conductors	[Quantity]	[Quantity]	[Quantity]
Diverse Route to POP?	[Yes, Build]	[Yes, Build]	[Yes, Build]
Diversity Method	[A, B, C, Other]	[A, B, C, Other]	[A, B, C, Other]
Provisioning Cost-Diverse	[Dollar Amount]	[Dollar Amount]	[Dollar Amount]
<b>Dedicated Services?</b>	[Yes, No]	[Yes, No]	[Yes, No]
Rate Table(s)	[Rate Table Number(s)]	[Rate Table Number(s)]	[Rate Table Number(s)]
Carrier(s) Providing	[Carrier ID(s)]	[Carrier ID(s)]	[Carrier ID(s)]
<b>Shared Services?</b>	[Yes, No]	[Yes, No]	[Yes, No]
Rate Table(s)	[Rate Table Number(s)]	[Rate Table Number(s)]	[Rate Table Number(s)]
Carrier(s) Providing	[Carrier ID(s)]	[Carrier ID(s)]	[Carrier ID(s)]

**SOHCN OARnet Facility Resposne Tables**

<b>OARnet Facility</b>	OARnet	OARnet	OARnet
<b>OARnet Facility ID</b>	Athens CityNet POP	Chillicothe AEP POP	Portsmouth EarthLink POP
Address City/State NPA-nxx	160 W Union St, HDL Center Suite 179A Athens, OH 740-593	701 Hardin Dr. Chillicothe, OH 740-774	800 Gallia St, National City Bank Portsmouth, OH 740-353
Primary Entry?	[Yes, Build]	[Yes, Build]	[Yes, Build]
Number of Fiber Strands	[Quantity]	[Quantity]	[Quantity]
Number of Copper Conductors	[Quantity]	[Quantity]	[Quantity]
Provisioning Cost-Primary	[Dollar Amount]	[Dollar Amount]	[Dollar Amount]
Diverse Entry?	[Yes, Build]	[Yes, Build]	[Yes, Build]
Number of Fiber Strands	[Quantity]	[Quantity]	[Quantity]
Number of Copper Conductors	[Quantity]	[Quantity]	[Quantity]
Diverse Route to POP?	[Yes, Build]	[Yes, Build]	[Yes, Build]
Diversity Method	[A, B, C, Other]	[A, B, C, Other]	[A, B, C, Other]
Provisioning Cost-Diverse	[Dollar Amount]	[Dollar Amount]	[Dollar Amount]
<b>Dedicated Services?</b>	[Yes, No]	[Yes, No]	[Yes, No]
Rate Table(s)	Rate Table Number(s)	Rate Table Number(s)	Rate Table Number(s)
Carrier(s) Providing	[Carrier ID(s)]	[Carrier ID(s)]	[Carrier ID(s)]
<b>Shared Services?</b>	[Yes, No]	[Yes, No]	[Yes, No]
Rate Table(s)	Rate Table Number(s)	Rate Table Number(s)	Rate Table Number(s)
Carrier(s) Providing	[Carrier ID(s)]	[Carrier ID(s)]	[Carrier ID(s)]

**SOHCN OARnet Facility Resposne Tables**

<b>OARnet Facility</b>	OARnet	OARnet	OARnet
<b>OARnet Facility ID</b>	State of Ohio Computer Center	State Office Tower	Borden Bldg Qwest POP
Address	1320 Arthur E. Adams Dr.	30 East Broad St. 7th Fl	180 E Broad St. Basement #2
City/State	Columbus, OH	Columbus, OH	Columbus, OH
NPA-nxx	614-488	614-466	614-456
Primary Entry?	[Yes, Build]	[Yes, Build]	[Yes, Build]
Number of Fiber Strands	[Quantity]	[Quantity]	[Quantity]
Number of Copper Conductors	[Quantity]	[Quantity]	[Quantity]
Provisioning Cost-Primary	[Dollar Amount]	[Dollar Amount]	[Dollar Amount]
Diverse Entry?	[Yes, Build]	[Yes, Build]	[Yes, Build]
Number of Fiber Strands	[Quantity]	[Quantity]	[Quantity]
Number of Copper Conductors	[Quantity]	[Quantity]	[Quantity]
Diverse Route to POP?	[Yes, Build]	[Yes, Build]	[Yes, Build]
Diversity Method	[A, B, C, Other]	[A, B, C, Other]	[A, B, C, Other]
Provisioning Cost-Diverse	[Dollar Amount]	[Dollar Amount]	[Dollar Amount]
<b>Dedicated Services?</b>	[Yes, No]	[Yes, No]	[Yes, No]
Rate Table(s)	Rate Table Number(s)	Rate Table Number(s)	Rate Table Number(s)
Carrier(s) Providing	[Carrier ID(s)]	[Carrier ID(s)]	[Carrier ID(s)]
<b>Shared Services?</b>	[Yes, No]	[Yes, No]	[Yes, No]
Rate Table(s)	Rate Table Number(s)	Rate Table Number(s)	Rate Table Number(s)
Carrier(s) Providing	[Carrier ID(s)]	[Carrier ID(s)]	[Carrier ID(s)]

**SOHCN OARnet Facility Resposne Tables**

<b>OARnet Facility</b>	OSCnet		
<b>OARnet Facility ID</b>	Columbus CityNet POP		
Address City/State NPA-nxx	251 N. Neilston Columbus, OH 614-469		
Primary Entry? Number of Fiber Strands Number of Copper Conductors Provisioning Cost-Primary	[Yes, Build] [Quantity] [Quantity] [Dollar Amount]	[Yes, Build] [Quantity] [Quantity] [Dollar Amount]	[Yes, Build] [Quantity] [Quantity] [Dollar Amount]
Diverse Entry? Number of Fiber Strands Number of Copper Conductors Diverse Route to POP? Diversity Method Provisioning Cost-Diverse	[Yes, Build] [Quantity] [Quantity] [Yes, Build] [A, B, C, Other] [Dollar Amount]	[Yes, Build] [Quantity] [Quantity] [Yes, Build] [A, B, C, Other] [Dollar Amount]	[Yes, Build] [Quantity] [Quantity] [Yes, Build] [A, B, C, Other] [Dollar Amount]
<b>Dedicated Services?</b> Rate Table(s) Carrier(s) Providing	[Yes, No] Rate Table Number(s) [Carrier ID(s)]	[Yes, No] Rate Table Number(s) [Carrier ID(s)]	[Yes, No] Rate Table Number(s) [Carrier ID(s)]
<b>Shared Services?</b> Rate Table(s) Carrier(s) Providing	[Yes, No] Rate Table Number(s) [Carrier ID(s)]	[Yes, No] Rate Table Number(s) [Carrier ID(s)]	[Yes, No] Rate Table Number(s) [Carrier ID(s)]

**SOHCN Community Broadband Response Tables**

<b>Service Area</b>	Albany	Athens	Bidwell
Size of Area	[Area in Square Miles]	[Area in Square Miles]	[Area in Square Miles]
Increase over Existing Service Area	[Area in Square Miles]	[Area in Square Miles]	[Area in Square Miles]
Geographic Boundary Points			
Point A	[Address or Geocode]	[Address or Geocode]	[Address or Geocode]
Point B	[Address or Geocode]	[Address or Geocode]	[Address or Geocode]
Point C	[Address or Geocode]	[Address or Geocode]	[Address or Geocode]
Point D	[Address or Geocode]	[Address or Geocode]	[Address or Geocode]
Point E	[Address or Geocode]	[Address or Geocode]	[Address or Geocode]
Point F	[Address or Geocode]	[Address or Geocode]	[Address or Geocode]
Point G	[Address or Geocode]	[Address or Geocode]	[Address or Geocode]
<b>Dedicated Services?</b>	[Yes, No]	[Yes, No]	[Yes, No]
Rate Table(s)	[Rate Table Number]	[Rate Table Number]	[Rate Table Number]
Percentage of Addresses Serviceable	[%]	[%]	[%]
<b>Shared Services?</b>	[Yes, No]	[Yes, No]	[Yes, No]
Rate Table(s)	[Rate Table Number]	[Rate Table Number]	[Rate Table Number]
Percentage of Addresses Serviceable	[%]	[%]	[%]
<b>Service Area</b>	Chesapeake	Chillicothe	Coal Grove
Size of Area	[Area in Square Miles]	[Area in Square Miles]	[Area in Square Miles]
Increase over Existing Service Area	[Area in Square Miles]	[Area in Square Miles]	[Area in Square Miles]
Geographic Boundary Points			
Point A	[Address or Geocode]	[Address or Geocode]	[Address or Geocode]
Point B	[Address or Geocode]	[Address or Geocode]	[Address or Geocode]
Point C	[Address or Geocode]	[Address or Geocode]	[Address or Geocode]
Point D	[Address or Geocode]	[Address or Geocode]	[Address or Geocode]
Point E	[Address or Geocode]	[Address or Geocode]	[Address or Geocode]
Point F	[Address or Geocode]	[Address or Geocode]	[Address or Geocode]
Point G	[Address or Geocode]	[Address or Geocode]	[Address or Geocode]
<b>Dedicated Services?</b>	[Yes, No]	[Yes, No]	[Yes, No]
Rate Table(s)	[Rate Table Number]	[Rate Table Number]	[Rate Table Number]
Percentage of Addresses Serviceable	[%]	[%]	[%]
<b>Shared Services?</b>	[Yes, No]	[Yes, No]	[Yes, No]
Rate Table(s)	[Rate Table Number]	[Rate Table Number]	[Rate Table Number]
Percentage of Addresses Serviceable	[%]	[%]	[%]

**SOHCN Community Broadband Response Tables**

<b>Service Area</b>	Columbus	Coolville	Gallipolis
Size of Area	[Area in Square Miles]	[Area in Square Miles]	[Area in Square Miles]
Increase over Existing Service Area	[Area in Square Miles]	[Area in Square Miles]	[Area in Square Miles]
<b>Geographic Boundary Points</b>			
Point A	[Address or Geocode]	[Address or Geocode]	[Address or Geocode]
Point B	[Address or Geocode]	[Address or Geocode]	[Address or Geocode]
Point C	[Address or Geocode]	[Address or Geocode]	[Address or Geocode]
Point D	[Address or Geocode]	[Address or Geocode]	[Address or Geocode]
Point E	[Address or Geocode]	[Address or Geocode]	[Address or Geocode]
Point F	[Address or Geocode]	[Address or Geocode]	[Address or Geocode]
Point G	[Address or Geocode]	[Address or Geocode]	[Address or Geocode]
<b>Dedicated Services?</b>	[Yes, No]	[Yes, No]	[Yes, No]
Rate Table(s)	[Rate Table Number]	[Rate Table Number]	[Rate Table Number]
Percentage of Addresses Serviceable	[%]	[%]	[%]
<b>Shared Services?</b>	[Yes, No]	[Yes, No]	[Yes, No]
Rate Table(s)	[Rate Table Number]	[Rate Table Number]	[Rate Table Number]
Percentage of Addresses Serviceable	[%]	[%]	[%]

<b>Service Area</b>	Greenfield	Hillsboro	Ironton
Size of Area	[Area in Square Miles]	[Area in Square Miles]	[Area in Square Miles]
Increase over Existing Service Area	[Area in Square Miles]	[Area in Square Miles]	[Area in Square Miles]
<b>Geographic Boundary Points</b>			
Point A	[Address or Geocode]	[Address or Geocode]	[Address or Geocode]
Point B	[Address or Geocode]	[Address or Geocode]	[Address or Geocode]
Point C	[Address or Geocode]	[Address or Geocode]	[Address or Geocode]
Point D	[Address or Geocode]	[Address or Geocode]	[Address or Geocode]
Point E	[Address or Geocode]	[Address or Geocode]	[Address or Geocode]
Point F	[Address or Geocode]	[Address or Geocode]	[Address or Geocode]
Point G	[Address or Geocode]	[Address or Geocode]	[Address or Geocode]
<b>Dedicated Services?</b>	[Yes, No]	[Yes, No]	[Yes, No]
Rate Table(s)	[Rate Table Number]	[Rate Table Number]	[Rate Table Number]
Percentage of Addresses Serviceable	[%]	[%]	[%]
<b>Shared Services?</b>	[Yes, No]	[Yes, No]	[Yes, No]
Rate Table(s)	[Rate Table Number]	[Rate Table Number]	[Rate Table Number]
Percentage of Addresses Serviceable	[%]	[%]	[%]

**SOHCN Community Broadband Response Tables**

<b>Service Area</b>	Jackson	Lucasville	Lynchburg
Size of Area	[Area in Square Miles]	[Area in Square Miles]	[Area in Square Miles]
Increase over Existing Service Area	[Area in Square Miles]	[Area in Square Miles]	[Area in Square Miles]
Geographic Boundary Points			
Point A	[Address or Geocode]	[Address or Geocode]	[Address or Geocode]
Point B	[Address or Geocode]	[Address or Geocode]	[Address or Geocode]
Point C	[Address or Geocode]	[Address or Geocode]	[Address or Geocode]
Point D	[Address or Geocode]	[Address or Geocode]	[Address or Geocode]
Point E	[Address or Geocode]	[Address or Geocode]	[Address or Geocode]
Point F	[Address or Geocode]	[Address or Geocode]	[Address or Geocode]
Point G	[Address or Geocode]	[Address or Geocode]	[Address or Geocode]
<b>Dedicated Services?</b>	[Yes, No]	[Yes, No]	[Yes, No]
Rate Table(s)	[Rate Table Number]	[Rate Table Number]	[Rate Table Number]
Percentage of Addresses Serviceable	[%]	[%]	[%]
<b>Shared Services?</b>	[Yes, No]	[Yes, No]	[Yes, No]
Rate Table(s)	[Rate Table Number]	[Rate Table Number]	[Rate Table Number]
Percentage of Addresses Serviceable	[%]	[%]	[%]

<b>Service Area</b>	McArthur	Nelsonville	Piketon
Size of Area	[Area in Square Miles]	[Area in Square Miles]	[Area in Square Miles]
Increase over Existing Service Area	[Area in Square Miles]	[Area in Square Miles]	[Area in Square Miles]
Geographic Boundary Points			
Point A	[Address or Geocode]	[Address or Geocode]	[Address or Geocode]
Point B	[Address or Geocode]	[Address or Geocode]	[Address or Geocode]
Point C	[Address or Geocode]	[Address or Geocode]	[Address or Geocode]
Point D	[Address or Geocode]	[Address or Geocode]	[Address or Geocode]
Point E	[Address or Geocode]	[Address or Geocode]	[Address or Geocode]
Point F	[Address or Geocode]	[Address or Geocode]	[Address or Geocode]
Point G	[Address or Geocode]	[Address or Geocode]	[Address or Geocode]
<b>Dedicated Services?</b>	[Yes, No]	[Yes, No]	[Yes, No]
Rate Table(s)	[Rate Table Number]	[Rate Table Number]	[Rate Table Number]
Percentage of Addresses Serviceable	[%]	[%]	[%]
<b>Shared Services?</b>	[Yes, No]	[Yes, No]	[Yes, No]
Rate Table(s)	[Rate Table Number]	[Rate Table Number]	[Rate Table Number]
Percentage of Addresses Serviceable	[%]	[%]	[%]

**SOHCN Community Broadband Response Tables**

<b>Service Area</b>	Pomeroy	Portsmouth	Proctorville
Size of Area	[Area in Square Miles]	[Area in Square Miles]	[Area in Square Miles]
Increase over Existing Service Area	[Area in Square Miles]	[Area in Square Miles]	[Area in Square Miles]
Geographic Boundary Points			
Point A	[Address or Geocode]	[Address or Geocode]	[Address or Geocode]
Point B	[Address or Geocode]	[Address or Geocode]	[Address or Geocode]
Point C	[Address or Geocode]	[Address or Geocode]	[Address or Geocode]
Point D	[Address or Geocode]	[Address or Geocode]	[Address or Geocode]
Point E	[Address or Geocode]	[Address or Geocode]	[Address or Geocode]
Point F	[Address or Geocode]	[Address or Geocode]	[Address or Geocode]
Point G	[Address or Geocode]	[Address or Geocode]	[Address or Geocode]
<b>Dedicated Services?</b>	[Yes, No]	[Yes, No]	[Yes, No]
Rate Table(s)	[Rate Table Number]	[Rate Table Number]	[Rate Table Number]
Percentage of Addresses Serviceable	[%]	[%]	[%]
<b>Shared Services?</b>	[Yes, No]	[Yes, No]	[Yes, No]
Rate Table(s)	[Rate Table Number]	[Rate Table Number]	[Rate Table Number]
Percentage of Addresses Serviceable	[%]	[%]	[%]

<b>Service Area</b>	Racine	Seaman	South Point
Size of Area	[Area in Square Miles]	[Area in Square Miles]	[Area in Square Miles]
Increase over Existing Service Area	[Area in Square Miles]	[Area in Square Miles]	[Area in Square Miles]
Geographic Boundary Points			
Point A	[Address or Geocode]	[Address or Geocode]	[Address or Geocode]
Point B	[Address or Geocode]	[Address or Geocode]	[Address or Geocode]
Point C	[Address or Geocode]	[Address or Geocode]	[Address or Geocode]
Point D	[Address or Geocode]	[Address or Geocode]	[Address or Geocode]
Point E	[Address or Geocode]	[Address or Geocode]	[Address or Geocode]
Point F	[Address or Geocode]	[Address or Geocode]	[Address or Geocode]
Point G	[Address or Geocode]	[Address or Geocode]	[Address or Geocode]
<b>Dedicated Services?</b>	[Yes, No]	[Yes, No]	[Yes, No]
Rate Table(s)	[Rate Table Number]	[Rate Table Number]	[Rate Table Number]
Percentage of Addresses Serviceable	[%]	[%]	[%]
<b>Shared Services?</b>	[Yes, No]	[Yes, No]	[Yes, No]
Rate Table(s)	[Rate Table Number]	[Rate Table Number]	[Rate Table Number]
Percentage of Addresses Serviceable	[%]	[%]	[%]

**SOHCN Community Broadband Response Tables**

<b>Service Area</b>	The Plains	Washington Court House	Waverly
Size of Area	[Area in Square Miles]	[Area in Square Miles]	[Area in Square Miles]
Increase over Existing Service Area	[Area in Square Miles]	[Area in Square Miles]	[Area in Square Miles]
Geographic Boundary Points			
Point A	[Address or Geocode]	[Address or Geocode]	[Address or Geocode]
Point B	[Address or Geocode]	[Address or Geocode]	[Address or Geocode]
Point C	[Address or Geocode]	[Address or Geocode]	[Address or Geocode]
Point D	[Address or Geocode]	[Address or Geocode]	[Address or Geocode]
Point E	[Address or Geocode]	[Address or Geocode]	[Address or Geocode]
Point F	[Address or Geocode]	[Address or Geocode]	[Address or Geocode]
Point G	[Address or Geocode]	[Address or Geocode]	[Address or Geocode]
<b>Dedicated Services?</b>	[Yes, No]	[Yes, No]	[Yes, No]
Rate Table(s)	[Rate Table Number]	[Rate Table Number]	[Rate Table Number]
Percentage of Addresses Serviceable	[%]	[%]	[%]
<b>Shared Services?</b>	[Yes, No]	[Yes, No]	[Yes, No]
Rate Table(s)	[Rate Table Number]	[Rate Table Number]	[Rate Table Number]
Percentage of Addresses Serviceable	[%]	[%]	[%]

<b>Service Area</b>	West Union	Winchester	
Size of Area	[Area in Square Miles]	[Area in Square Miles]	[Area in Square Miles]
Increase over Existing Service Area	[Area in Square Miles]	[Area in Square Miles]	[Area in Square Miles]
Geographic Boundary Points			
Point A	[Address or Geocode]	[Address or Geocode]	[Address or Geocode]
Point B	[Address or Geocode]	[Address or Geocode]	[Address or Geocode]
Point C	[Address or Geocode]	[Address or Geocode]	[Address or Geocode]
Point D	[Address or Geocode]	[Address or Geocode]	[Address or Geocode]
Point E	[Address or Geocode]	[Address or Geocode]	[Address or Geocode]
Point F	[Address or Geocode]	[Address or Geocode]	[Address or Geocode]
Point G	[Address or Geocode]	[Address or Geocode]	[Address or Geocode]
<b>Dedicated Services?</b>	[Yes, No]	[Yes, No]	[Yes, No]
Rate Table(s)	[Rate Table Number]	[Rate Table Number]	[Rate Table Number]
Percentage of Addresses Serviceable	[%]	[%]	[%]
<b>Shared Services?</b>	[Yes, No]	[Yes, No]	[Yes, No]
Rate Table(s)	[Rate Table Number]	[Rate Table Number]	[Rate Table Number]
Percentage of Addresses Serviceable	[%]	[%]	[%]